

# TABLE OF CONTENTS

<u>QUICK START</u>	<u>2</u>
<u>PRODUCT DESCRIPTION</u>	<u>4</u>
Applicator Specifications	5
Options	6
<u>SHIPMENT CONTENTS</u>	<u>7</u>
<u>SAFETY INSTRUCTIONS</u>	<u>8</u>
<u>SETUP / INSTALLATION</u>	<u>10</u>
Tools Required	
Setup	
<u>APPLICATOR SETUP</u>	<u>18</u>
Tamp Orientation	18
Tamp Angle / Speed / Pressure	22
Custom Tamp Pad	24
Printer Setup	28
Software Setup	29
<u>FUNCTIONS</u>	<u>30</u>
LEDs	32
Operation	37
Label Synchronization	38
15 Pin Sub-D I/O Port	39
Input / Output Description	40
Signal Explanation	41
<u>APPLICATION NOTES</u>	<u>47</u>
<u>FIRMWARE</u>	<u>48</u>
<u>TROUBLESHOOTING</u>	<u>50</u>
Error Conditions, Causes and Solutions	50
Problems, Causes and Solutions	54
Common Problems with Setup or Media	57
<u>WARRANTY INFORMATION</u>	<u>67</u>
<u>INDEX</u>	<u>69</u>

## **Quick Start**

The PA1000t Tamp Applicator is easy to assemble and use. The following is a summary of the necessary steps to get the applicator up and running.

If this is the first time you are setting up a PA1000t, it is recommended that you read the entire manual for more detailed instructions and tips for trouble-free assembly.

### 1. T-base Stand

- A. Unpack the applicator's T-base stand
- B. Assemble the T-base stand

### 2. Printer

- A. Unpack the printer
- B. Place the printer on stand, making sure to align the table pins with the printer index holes
- C. Lock down the printer to the table with the slide locks on the bottom of the table

### 3. Applicator

- A. Mount the applicator to the table
- B. Connect applicator to the printer's peripheral port
- C. Punch holes in the pad for your label size
- D. Attach the pad to the applicator

### 4. Install Trigger Device (sensor, foot switch or PLC)

- A. Plug in the optical sensor, foot switch or PLC that will be triggering the applicator
- B. Mount the triggering device as appropriate

### 5. Load Media

- A. Load label stock in printer
- B. Load ribbon in printer

### 6. Apply Air

- A. Attach the air filter/regulator to the T-base stand
- B. Connect the blow tube
- C. Connect the filter/regulator to the applicator
- D. Apply your supply air to the filter/regulator
- E. Remove the O-ring that is holding the pad in place during shipping

**WARNING! When air is being applied, keep fingers and hands away from moving parts.**

## **Quick Start (cont'd)**

### 7. Apply Power

- A. Attach power cord to the printer
- B. Plug power cord into a grounded outlet

### 8. Configure Printer

- A. Change backfeed setting to 'always' in printer's front panel setup
- B. Set "24V on:" using HyperTerminal. Set this to "permanent" (this should be factory set, see maintenance manual if a change is necessary).

### 9. Configure Software

- A. Create EASYLABEL format, or directly program the format as follows:
  - print mode = peel off
  - presentation position = 6 to 12
  - print speed = 5.2ips
  - label offset = .00

### 10. Send Label Job to Printer

- A. Download a job to the memory card, or send a print job to the printer
- B. Select a job from the memory card if the printer is in stand-alone mode

### 11. Print and Apply

- A. When the printer front panel displays "Printing label no. 1", the system is ready to be triggered by a start signal. Turn on the conveyor, or place the product in the work cell and test the operation. If using the PA1000t with a conveyor, adjust the triggering device as necessary to place the label in the desired position on the product.

## **Product Description**

The PA1000t Tamp Applicator is an accessory manufactured specifically for use with the Apollo label printer for automatically applying a printed label to a product. The labels are applied with a tamp pad by means of a pneumatic cylinder that moves between two positions, the starting position and the labeling position. A switching device that is connected to the applicator's PLC port will initiate the print and apply cycle. This device may be a foot switch, optical sensor or PLC (Programmable Logic Controller).

The label is removed from the carrier directly at the dispense edge of the printer. A sensor on the cylinder signals when the tamp pad is in the starting position. From this position, the label is picked up from the printer by the vacuum plate of the pad. The pad consists of holes on the bottom side so that when the printer feeds the labels out, the vacuum can pull the labels onto the pad. For support purposes, the label is also blown against the pad by an air current supplied by a blow bar.

A vacuum sensor ensures controlled label handling and positioning on the pad. The pad is moved down into the labeling position, which is confirmed by another sensor (down position sensor). From this position, the pad makes controlled contact with the product and the label is released from the pad. The PA1000t is unique because it can detect and apply a label to products varying in height by as much as 8 inches. In side-apply situations, products can also vary in depth by as much as 8 inches.

If the vacuum sensor does not detect a label on the tamp pad when the cylinder starts its apply motion, or if it detects a vacuum blockage while starting its return motion, an error message will be displayed and the apply cycle will pause. Other printer errors, such as out of ribbon or labels, will also cause the operation to stop.

The printer's peripheral connector is used to attach the control unit of the applicator to the Apollo printer. Our unique front panel design allows easy and constant monitoring of the printer and applicator operating status. Based on which colored LED is lit, you can quickly determine and correct an error condition, thereby keeping down time to a minimum.

Another unique feature of the PA1000t is the ability to up-grade the applicator's firmware version directly on the circuit board by connecting the applicator controller to the serial port on a PC. The most current firmware version can be downloaded from the World Wide Web. (*This feature will not be available until the third quarter of 2000*).

11 LED indicators on the applicator controller board are visible through the dark front cover when lit. The LEDs can display the firmware version in the controller as well as indicate various conditions or operations that are described throughout this manual.

There are two buttons on the side of the applicator. The red button is the reset button and serves the same purpose as powering down the printer. The black button is a one-step button used to manually break the print and apply sequence into two separate steps. This will allow for easy re-sequencing of the applicator after a paper out, ribbon out and/or other error conditions.

**Product Description (cont'd)**

Applicator Specifications

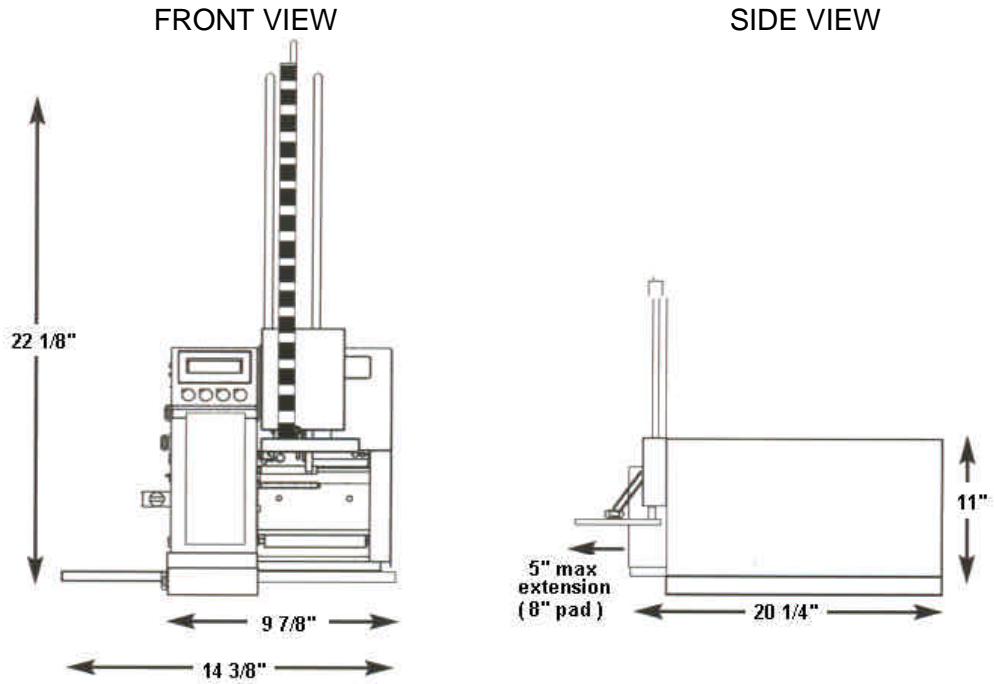

- Minimum Size Label: 2" x 1" (50 x 25mm)
- Maximum Size Label: 4 1/2" x 8" (114.3 x 200mm)
- Speed: Up to 60 labels per minute
- Weight: Applicator with table: 25 lbs. (11.5 KG)
- Stand Only: 95 lbs. (43.0 KG)
- Tamp Pad Sizes: 4" (101.6mm), 6.5" (165.1mm), 8" (203mm)
- Stroke Length: 15" (381mm) (10" (254mm) below table)
- Variable Height: Stroke length is automatically varied. The pad will stop moving and return to the up position when contact with product is made. A mechanical adjustment on the tamp head allows setting of the tamp pressure.

**MAXIMUM LABELS PER MINUTE\***

Size	Apollo 1	Apollo 2
4" x 2"	56	56
4" x 4"	42	42
4" x 6"	35	35

\* Based on Printer type, Label size, stroke length and conveyor speed. These results were achieved with a 9" stroke (2" below table). Full back feed between each label. Each label was unique.

## **Product Description (cont'd)**

### Options

Warning Beacon:	Informs operator of error condition or out of stock condition <i>Please see Page 62 for a detailed description</i>
Product Sensor:	Triggers applicator upon detecting a product <i>Please see Page 63 for a detailed description</i>
Product Sensor Timer:	Can delay the triggering of the applicator to be timed for specific label placement on a product. This timer is also used to send a continuous stream of start pulses for use in applications using a scale. <i>Please see Page 64 for a detailed description</i>
Foot Switch:	For manually triggering the applicator <i>Please see Page 65 for a detailed description</i>
PCMCIA Memory Card:	For storing downloadable formats for stand-alone printing
Keyboard Adapter:	For plugging an external keyboard or bar code wedge into the printer for stand-alone printing
Repositionable Printer Control Panel:	For easier operator access and viewing
Hand Cranked Height Adjustable T-Base Stand:	Allows for extremely precise height adjustment. Stand is equipped with lockable wheels for easy movement of system to another line.
Optional Stand-Alone Capability:	The PA1000t also features the ability to work with or without a computer attached, giving you much more flexibility in meeting all labeling requirements. This stand-alone feature eliminates the need for additional computers, is ideal for print and apply applications in remote locations, saves workspace, and is even perfect for use in harsh working environments!

EASYLABEL® Label Design Software

## **Shipment Contents**

(For easy assembly, open boxes in numerical order starting with Box 1)

### **BOX 1 Contents**

- (A) Short (24") rectangular bar with base clamp
- (B) Long (36") rectangular bar



### **BOX 2 Contents**

- (C) Short (36") round bar (yard arm)
- (D) Long (54") round bar with side arm clamp (mast)
- (E) Table clamp



### **BOX 3 Contents**

- (F) Printer support plate with locks and guide pins

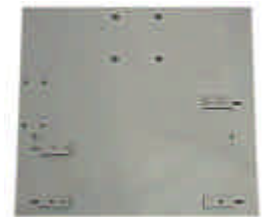

### **BOX 4 Contents**

- (G) Applicator



### **BOX 5 Contents**

- (H) Apollo printer with applicable accessories  
*(Please refer to the shipment contents checklist in the "Printers Operators Manual")*



### **BOX 6 Contents**

- (I) Tamp pad
- (J) Air service unit
- (K) Applicator plate
- (L) Core adapter
- (M) Regulator hose
- (N) Peel plate

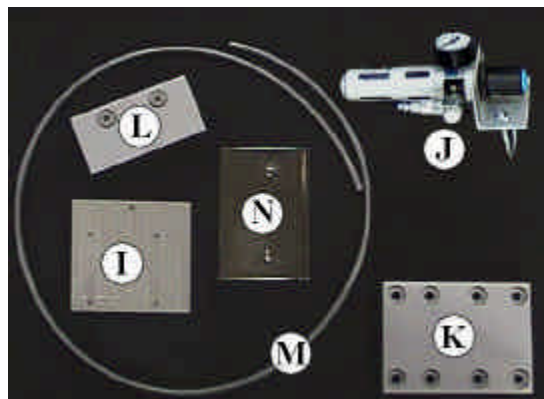

## **Safety Instructions**

**Warning! There is a danger of injury with this equipment.  
Do not reach into the area of any moving parts  
when turning on the air pressure or during operation.**

Keep long hair, loose clothing and jewelry away from all moving parts.

Observe all printer safety precautions as described in the “printer’s user” manual.

Please note the weight of the unit when assembling and adjusting the printer and applicator since several procedures will actually require two people. (e.g., when adjusting the height or position of the printer and applicator).

The printer and applicator must be placed on the T-base stand in a manner that will support the weight of the unit. This is accomplished by positioning the printer and applicator over one of the three legs of the stand. Observe the unit's center of gravity and configure it appropriately to prevent tipping. It is suggested that the stand be fastened to the conveyor or work cell. This can help to prevent any vibration, accidental movement or tipping from interrupting normal operation.

When the front cover of the applicator is open or removed, avoid using conductive tools on or around the applicator mainboard to avoid electrical shock and damage to the mainboard! Replace and close the applicator's front cover as soon as possible.

Do not plug the Apollo printer power cord into the electrical / power unit until all internal cable connections have been properly attached and the installation process has been completed. Plugging in any of the device cables when electrical power is present can ultimately damage the electronics.

Before the initial power up, remove the black O-ring used to hold the applicator stable during shipping and installation. Verify that the air service unit and the shut-off valve for the applicator are closed. Make sure that the tamp pad is held in the up position by the air pressure in the pneumatic cylinder. Once the O-ring has been removed, there will be no lock to secure the tamp pad in the up position when the power and air pressure are turned off.

If you are using the applicator in conjunction with a conveyor, we strongly suggest that a “Kill Switch” be installed to stop the conveyor instantly in case a problem occurs.

If the PA1000t needs service, contact the Tharo Systems PA1000t tech support at 330-273-4408 or contact us online at: [tharo@tharo.com](mailto:tharo@tharo.com).

## **Safety Instructions (cont'd)**

Safe and consistent operation of the PA1000t can be achieved by incorporating a regular preventative maintenance schedule. Depending on the amount of use and the environment in which the unit is operating, the following routine should be performed daily or weekly:

### 1. CLEANING

Keep foreign materials, such as dirt, dust and liquids, out of the path and surfaces of moving parts, the printer's paper path and printhead, and off of any sensors. Vacuum or blow away any such build-up.

### 2. DRAINING

Drain the air regulator, as needed. If your supply air is equipped with a manual drain, it is recommended that you drain any water from it (refer to the manual or documentation that was included with your air supply equipment for further instructions). It may be necessary to install an additional air and oil filter if your air supply is not dry and free of oil. Both water and oil in the supply air can shorten the life of some applicator parts.

### 3. VISUAL INSPECTION

Check for any loose or broken parts. If damage is detected, service the unit immediately! Because of the nature of this unit and the surrounding environment, the PA1000t and the Apollo printer are often subjected to repetitive blows and vibrations that can ultimately loosen mechanical fasteners. Although great care has been taken to avoid this, it is still recommended that screws and bolts be checked regularly to ensure safe and consistent operation.

### 4. GUIDE ROD MAINTENANCE

Apply 3 in One™ oil to the guide rods as necessary to prevent corrosion, especially during extended down time, shipping, or storage of the unit.

## Setup / Installation

### Tools Required:

- 1.5 mm Allen Wrench
- 3 mm Allen Wrench
- 5 mm Allen Wrench
- 6 mm Allen Wrench
- 1/8" Allen Wrench
  
- 13 mm Combination Wrench
- 17 mm Combination Wrench
- 19 mm Combination Wrench
  
- ½ Combination Wrench *or* Medium Crescent Wrench

### Setup

1. Remove 4 bolts from open end of short bar with base clamp (A)



2. Insert long bar (B) into opening in short bar (A)

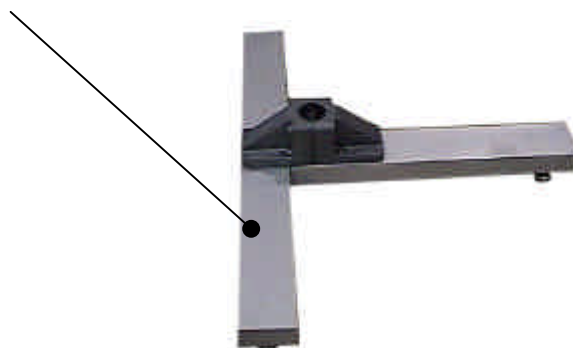

**Setup / Installation (cont'd)**

3. Loosen 4 bolts on side of base clamp to insert main mast (D)

4. Insert main mast (D) into opening in base clamp

5. Tighten the 4 bolts evenly to secure main mast in base clamp  
*(snug up one, then the diagonally opposite one, then the next two)*

6. Insert 4 bolts into base clamp and tighten securely

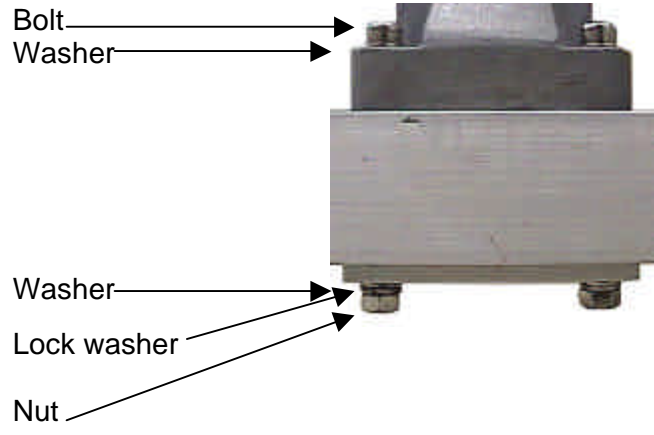

7. Insert yard arm (C) into side arm clamp and tighten securely



## Setup / Installation (cont'd)

8. Remove the 4 bolts from table clamp (E)

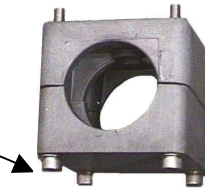

9. Attach table clamp (E) to printer support plate with 4 bolts but **do not** tighten  
*(The orientation of the table clamp on the support plate will vary depending on application... please see TAMP ORIENTATION)*

Please note: Nuts for the 4 table clamp bolts sit in the recess in the table clamp



10. Slide the printer support plate with table clamp attached onto table support pole (C) and tighten the 4 bolts evenly.

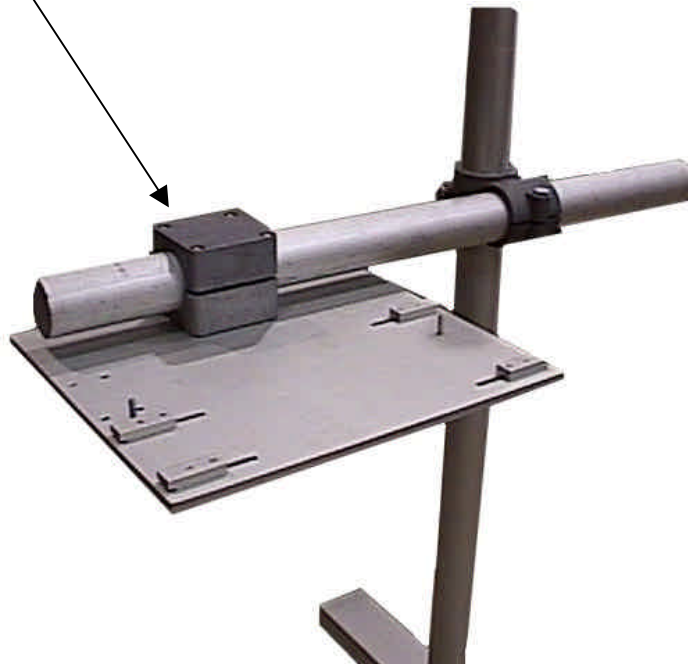

## Setup / Installation (cont'd)

11. Place printer on stand, making sure to align the table pins with the printer index holes

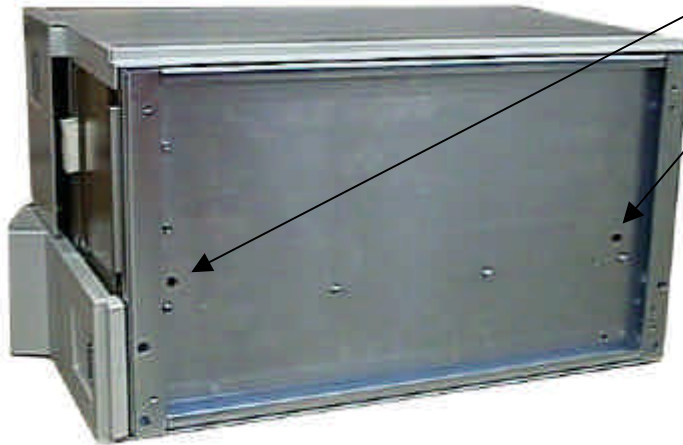

12. Lock down the printer to the table with the slide locks on the bottom of the table

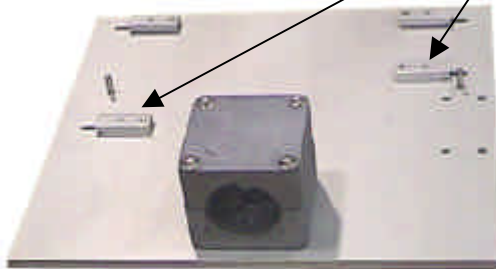

**Note:** First, slide the slide locks towards the inside of the table. Then, after setting the printer onto the table, slide the slide locks under the lip of the printer and secure with the slide lock bolts from under the table

13. Open the door of the printer and rotate the plate release lever clockwise.



## Setup / Installation (cont'd)

14. Remove the printer tear plate and replace it with the peel plate (N)

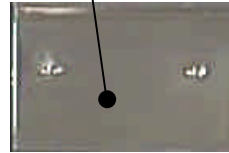

Secure the peel plate by turning the lever counter-clockwise

15. Mount applicator plate (K) to the printer support using the 4 short (22mm) bolts



16. Mount the applicator (G) to the applicator plate (K) using the 4 long (38mm) bolts

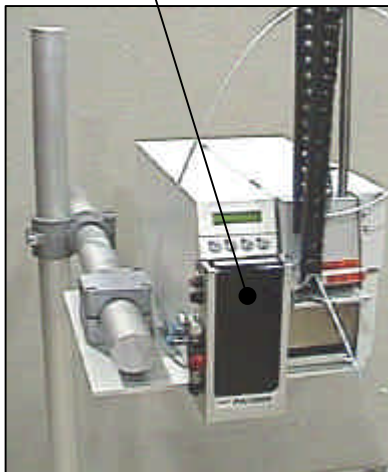

## Setup / Installation (cont'd)

17. Loosen the cover set screw and remove the applicator front cover to reveal the printer's peripheral port

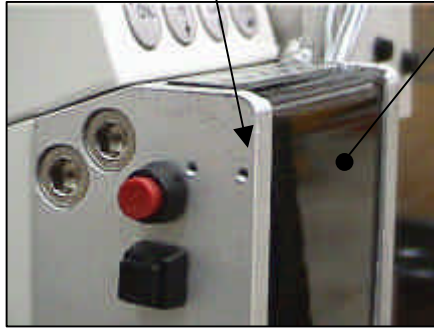

18. Connect the applicator's 15-pin sub-d connector to the printer's peripheral port

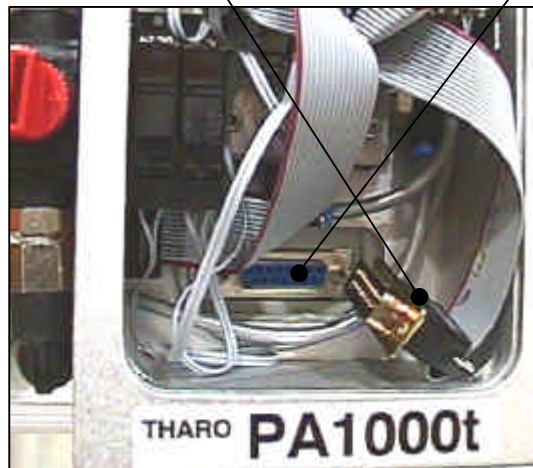

19. Replace the applicator's front cover and tighten the cover set screw

20. Remove the 4 screws from the top of the tamp pad (I)

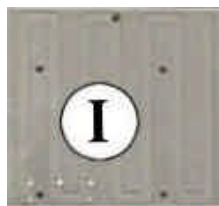

## Setup / Installation (cont'd)

21. Remove the black shipping O-ring and gently lower the applicator arm



22. Mount the tamp pad (I) to the lower spring plate of the applicator arm with the 4 screws removed from the tamp pad in #20

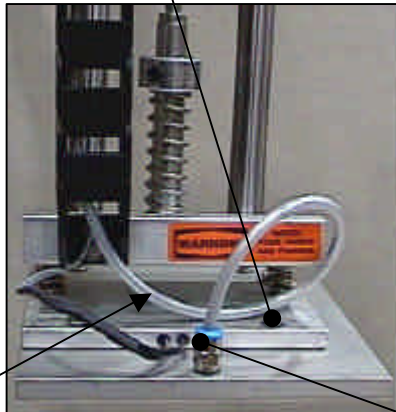

23. Slide the vacuum line coming from the applicator arm into the quick-connect fitting on the tamp pad

24. Attach the air regulator unit (J) to the main mast by sliding the u-bolt bracket over the top of the main mast. Once the bracket is placed in the desired position on the main mast, tighten the 2 nuts



## Setup / Installation (cont'd)

25. Slide one end of the regulator hose (M) into the quick-connect fitting on the applicator

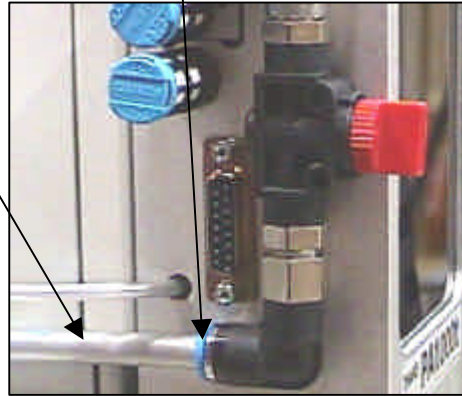

26. Slide the other end of the hose into the quick-connect fitting on the air regulator (J)



27. Insert the open end of the blow tube into the quick-connect fitting on the blow bar

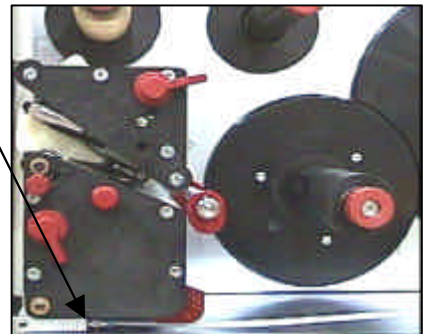
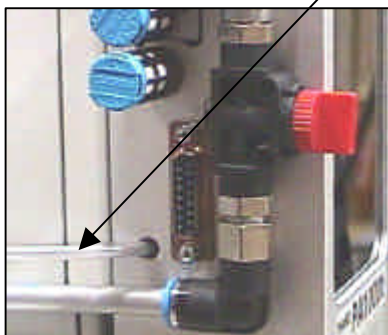

## Applicator Setup

### Tamp Orientation

The PA1000t can apply labels in the following four orientations:

1. Top apply with the applicator across the conveyor or work cell



(applicator in upright position across conveyor)

In this configuration, the label height is across the conveyor or work cell.

In order to configure the applicator for this type of application, place the table bracket on the table with the opening intersecting the printer. Attach the table to the yardarm with the printer in an upright position. Be sure to slide the yardarm completely into the table bracket before tightening. To prevent the stand from tipping, it is best to keep the printer and applicator as close to the mast of the stand as possible. Adjust this as necessary by loosening the yardarm side of the cross bracket attached to the mast and sliding the yardarm.

**Caution! When loosening the cross bracket, always have a second person hold the printer securely in place so that it cannot fall or tip in order to prevent personal injury and equipment damage.**

## Applicator Setup (cont'd)

2. Top apply with the applicator in line with conveyor or work cell



(applicator in upright position with conveyor)

In this configuration, the label height is with the conveyor or work cell.

In order to configure the applicator for this type of application, place the table bracket on the table with the opening in line with the printer. Attach the table to the yardarm with the printer in an upright position and with the back of the printer facing toward the mast. Be sure to slide the yardarm completely into the table bracket before tightening.

To prevent the stand from tipping, it is best to keep the printer and applicator as close to the mast of the stand as possible. Adjust this as necessary by loosening the yardarm side of the cross bracket attached to the mast and sliding the yardarm as needed.

**Caution! When loosening the cross bracket, always have a second person hold the printer securely in place so that it cannot fall or tip in order to prevent personal injury and equipment damage.**

## Applicator Setup (cont'd)

3. Side apply with the applicator on its tail

(applicator on its tail)



In this configuration, the label height is up and down on the side of the conveyor or work cell.

In order to configure the applicator for this type of application, place the table bracket on the table with the opening intersecting the printer. Attach the table to the yardarm with the printer on its tail. Be sure to slide the yardarm completely into the table bracket before tightening.

To prevent the stand from tipping, it is best to keep the printer and applicator as close to the mast of the stand as possible. Adjust this as necessary by loosening the yardarm side of the cross bracket attached to the mast and sliding the yardarm as needed.

**Caution! When loosening the cross bracket, always have a second person hold the printer securely in place so that it cannot fall or tip in order to prevent personal injury and equipment damage.**

When using the applicator in this orientation, it is necessary to attach the core adapter to the label supply shaft on the Apollo. This will prevent the label supply roll from hanging up or dragging on components inside the printer. The core adapter should be installed as illustrated below:



(core adapter in tail orientation)

## Applicator Setup (cont'd)

4. Side apply with the applicator on its side

(applicator on its side)



In this configuration, the label height is side to side with the conveyor or work cell.

In order to configure the applicator for this type of application, place the table bracket on the table with the opening in line with the printer. Attach the table to the yardarm with the printer on its side, and with the back of the printer facing toward the mast. Be sure to slide the yardarm completely into the table bracket before tightening. To prevent the stand from tipping, it is best to keep the printer and applicator as close to the mast of the stand as possible. Adjust this as necessary by loosening the yardarm side of the cross bracket attached to the mast and sliding the yardarm as needed.

**Caution! When loosening the cross bracket, always have a second person hold the printer securely in place so that it cannot fall or tip in order to prevent personal injury and equipment damage.**

When using the applicator in this orientation, it is necessary to attach the core adapter to the label supply shaft of the Apollo. This will prevent the label supply roll from hanging up or dragging on components inside the printer. The core adapter should be installed as illustrated below:



(core adapter in side orientation)

## Applicator Setup (cont'd)

### Tamp Angle

The PA1000t has a slight angle so that the pad travels away from the printer. This angle must be compensated for at the pad / product contact point.

**Please note that the tamp pad should come into contact with the product as flatly as possible.**

This can be accomplished by turning off the supply air and manually moving the pad onto the product (simulate the apply as closely as possible). Adjust the applicator by moving the whole stand, or by loosening the yard arm side of the cross bracket attached to the mast. Rotate the yard arm as needed to compensate for any angle between the pad and the product.

**Caution! When loosening the cross bracket, always have a second person hold the printer securely in place so that it cannot fall or tip in order to prevent personal injury and equipment damage.**

Please note that the pad is designed to flex to the angle of the product. This particular feature is intended to compensate for the occasional crooked product. This pad has not been designed to withstand constant flexing if the maximum life is desired from the applicator. Therefore, it is recommended that the pad be aligned as flatly as possible with the product to which the label is being applied.

### Tamp Speed

The speed of the down stroke and up stroke are factory set. However, some applications may require adjustment to the following settings:

#### **Down stroke speed**



Turn this valve counter-clockwise to increase speed, or clockwise to decrease speed.

## Applicator Setup (cont'd)

Factory set to –

This is roughly set by turning the valve clockwise until snug, and then turning it five full turns counter-clockwise.

### Up stroke speed



Turn this valve counter-clockwise to increase speed, or turn it clockwise to decrease speed.

Factory set to –

This is roughly set by turning the valve clockwise until snug, and then turning it four full turns counter-clockwise.

To manually test the cylinder:

Slide the applicator's front cover up enough to expose the manual valve buttons.

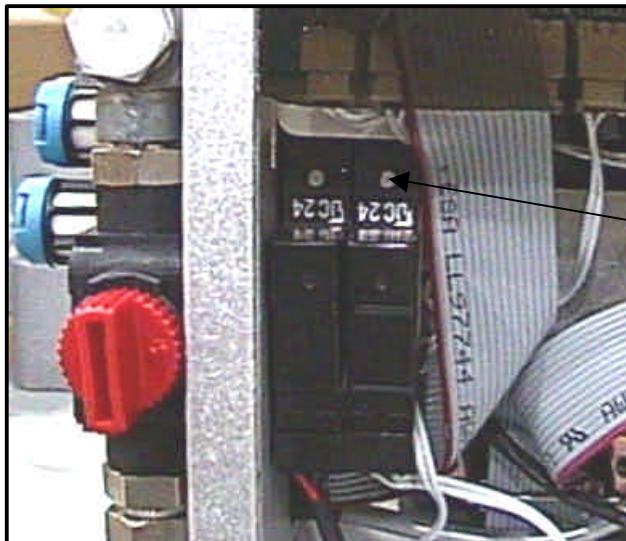

With the air on, press the desired button to manually open the valve actuating either the vac/blow (left button) or the cylinder (right button).

## Applicator Setup (cont'd)

### Tamp Pressure

The tamp pressure is set by an adjustment located on the cylinder shaft. This is factory set and adjustments in the field should not be necessary.

To increase or decrease the tamp pressure,

loosen the 1/8" set screw

on the collar.

Push the collar down to compress the spring and cause more tamp pressure, or slide the collar up and relieve the spring pressure to cause less tamp pressure. Retighten the set screw. Make sure to tighten the screw enough to prevent the collar from sliding or moving during use.

Note that the tamp pressure is also effected by the cylinder stroke speed and the applicator orientation. When changes are made to the stroke speed or orientation, the tamp pressure may need to be adjusted. It is best to set the tamp pressure to a point in which the pad just applies the label. Excessive tamp pressure will cause unnecessary stress and wear of the applicator.

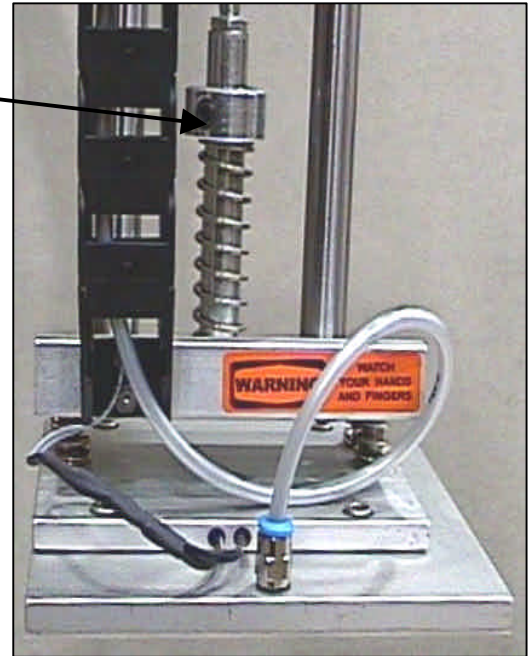

### Custom Tamp Pad

There are three standard pad sizes available for the PA1000t:

4.5" x 4"	114.3mm x 101.6mm
4.5" x 6.5"	114.3mm x 165.1mm
4.5" x 8"	114.3mm x 203.2mm

You should select the closest size that is equal to or larger than the labels that you will be applying.

## Applicator Setup (cont'd)

The customizable tamp pad comes pre-fitted with a nonstick plastic surface that can be made to fit your label size. This is accomplished by using the hole punch (included) and by piercing holes in the pad at the channel in the correct area that corresponds to your label size.

Please note the following:

Care should be taken when handling the pad to prevent damage or separation of the plastic from the pad, which could cause a poor vacuum seal and not allow the applicator to function properly.

**Do not** punch holes exactly on the edge of the label or in any area that will not be covered by the label, otherwise **the pad will not work!**

Before punching the holes in the pad within the channel, place the pad on the applicator and line up the screw holes with the holes on the lower spring plate. The corner closest to the printer and applicator is the 0,0 point.

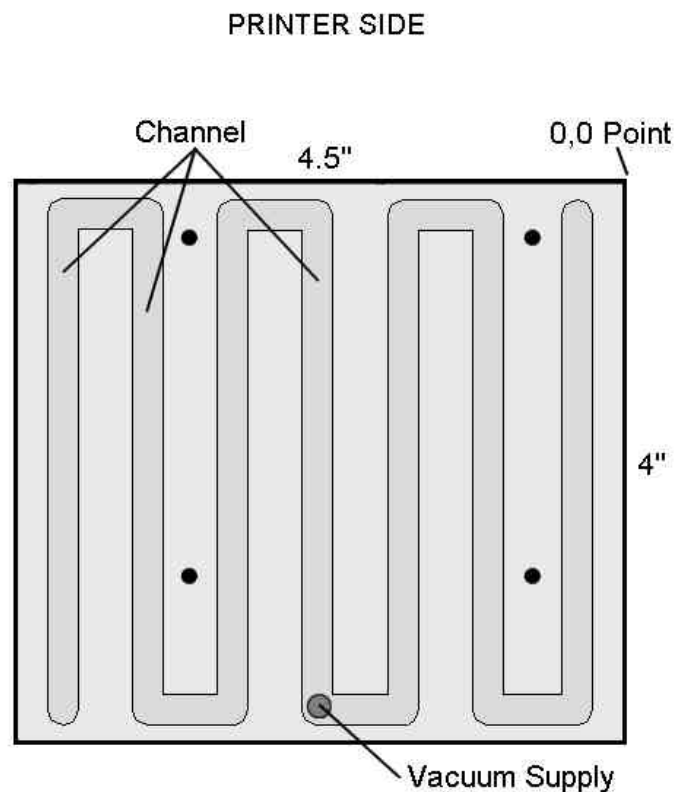

To correctly punch your pad:

1. Begin by placing the pad plastic side up, as shown in the diagram on the previous page.

2. Place your label onto the pad, making sure that the corner of the label is at the 0,0 point. From the PRINTER SIDE edge of the pad, measure down the length of the label 4mm. Then measure 9mm inwards from the APPLICATOR SIDE edge.

Punch a hole at this point within the center of the channel.  
Make sure that the piece of pad that is punched out is removed from the pad.  
If it is not, it may clog the vacuum.

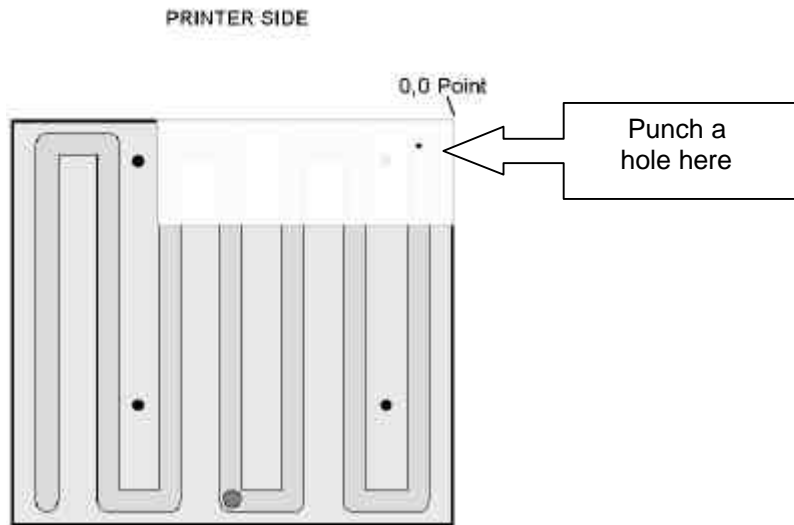

4. Measure down the left edge of the label 4mm and punch a hole within the center of the channel, making sure that the hole is not on the edge of the label. If it is on the edge, move further inwards to the next channel and punch a hole 4 mm down from the Printer Side of the pad.

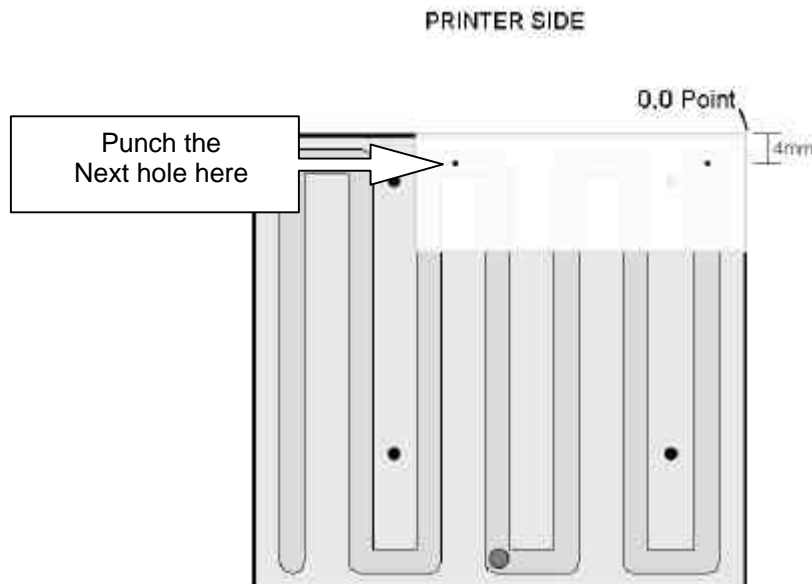

**Important:** Regardless of your label width, there should **NEVER** be more than 2 holes on the PRINTER SIDE edge of the pad.

- Measure 11mm in from the leading edge of the label (the edge closest to you at this point) and punch holes in every channel. Make sure that any hole that might be on the edge of the label is moved into the next channel within your label.

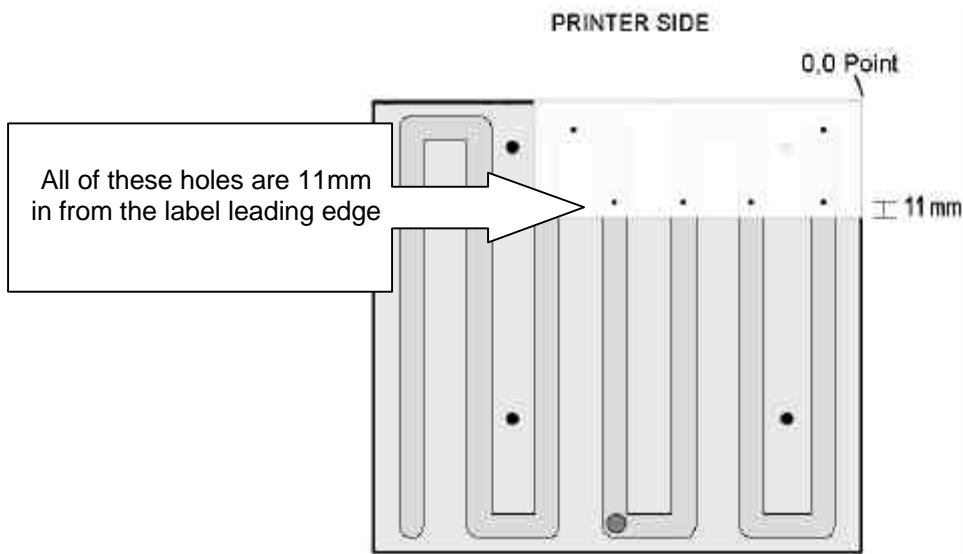

This pad is properly punched for a 3" x 1" label.

Please note:

For labels 3 inches in length or less, punch a hole in every channel across the leading edge of the label.

For labels 3 inches in length or more, never punch more than 4 holes on the leading edge.

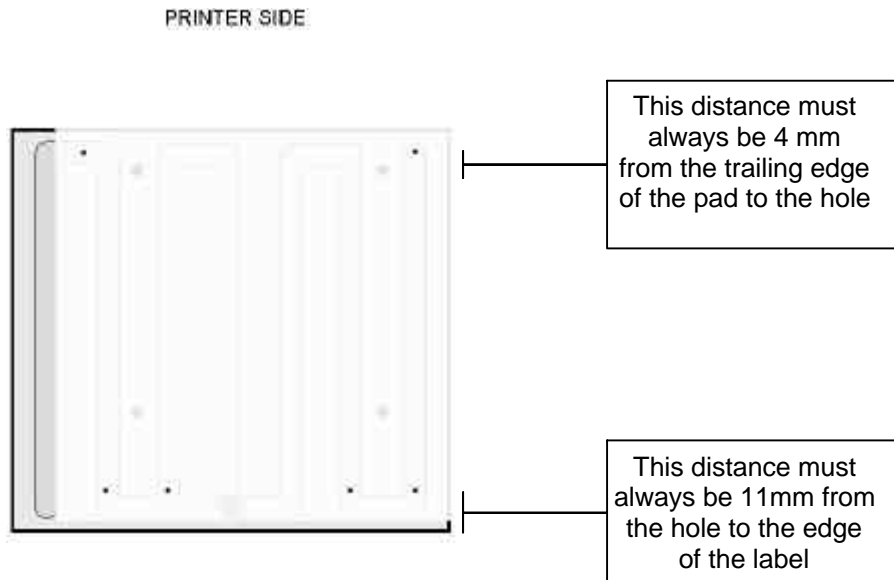

This pad is properly punched for a 4" x 4" label.

## Applicator Setup (cont'd)

### Printer Setup

The printer must be configured through its front panel in order for the applicator to work correctly.



To enter the printer configuration, press and hold the **ONL** and **CAN** buttons on the front panel for three seconds.

The LCD display should read **Setup**, then change to **Country**. From here you can scroll through the menu and make the following change if this setting is not already made:

Apollo 1	Backfeed	Head down, Always
Apollo 2	Backfeed	Always

Please refer to the printer manual for more detailed instructions on printer configuration.

If the backfeed setting is set to smart, you may see a white line running across the label if there are fields near the bottom of the label.

If the applicator is being used on a conveyor, and backfeed is set to smart, the first and possibly the second label printed will be applied in a different place than the rest of the labels in the job.

Load the labels and ribbon in the printer.

Please refer to the printer's manual for more detailed instructions on loading media.

Note- there is an option in the printer to turn on 24V on the peripheral port only during printing. The printer should be factory set to keep the 24V on all of the time.

If this setting should need changed, please refer to the Apollo maintenance manual.

## Applicator Setup (cont'd)

### Software Setup

Formats used with the PA1000t must be configured as follows for the applicator to work correctly:

In EASYLABEL® Software	Direct Apollo Programming
Label offset = .00	Label Offset is defined using the S command. The third parameter in the S command is vertical offset. A positive or negative value will move print up or down the label.  S l1; 0, <b>0.50</b> ,6.00, 6.10, 4.00
Print speed = 5.2ips	Print Speed is defined using the H command. The first parameter for the H command is print speed. If an incorrect value is entered, the printer will default to the closest value.  H <b>5.2</b> ,0,T
Print mode = peel off	The P Command will set the printer to Peel Mode
Presentation position = 6 to 12	A value in either inches or millimeters following the P command will set the Presentation Position. This can be a positive or negative value.

The value of the presentation position is the suggested starting point. This value may need to be adjusted due to slight mechanical differences from printer to printer.

To adjust to the correct presentation position, press the OneStep button and observe the second label back. It should approach the peel edge to as close as 1mm. If the label passes the peel edge, or if it is closer than 1mm, decrease the presentation position value. If the label is back from the peel edge by more than 1mm, increase the presentation position.

Running at print speeds higher than 5.2ips may cause a label to be skipped. If, however, the print area height is reduced by .05", it may be possible to run the unit at these higher speeds with no problem.

Please refer to the EASYLABEL manual or online help for more detailed information on format changes and configuration.

## Function

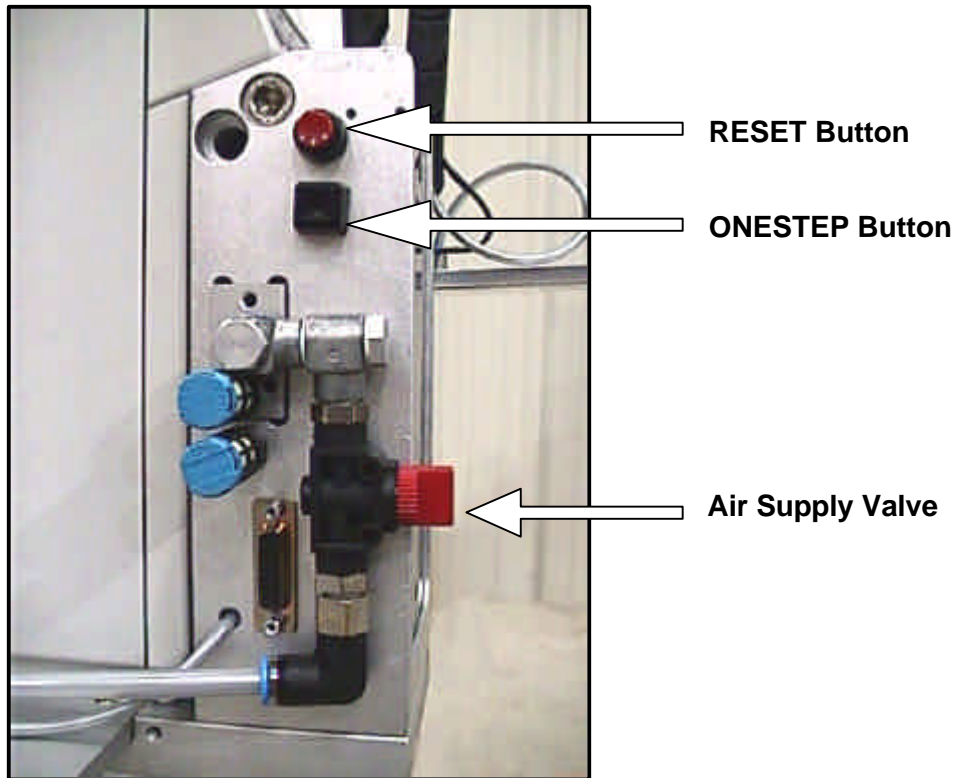

**Reset Button** (round red button, top left side of unit)

This button is used to perform the following functions:

1. Reset an applicator error

If an applicator error occurs, it must be cleared by pressing the reset button. As soon as the reset button is released, the applicator resets itself and performs a vacuum test, which is audible as two quick bursts of air. If there is no blockage in the vacuum, the applicator will be ready to resume normal operation.

2. Stop operation of the applicator at any time

Pressing the reset button at any time immediately stops the applicator. The emergency stop condition is sustained as long as the button is pressed. As soon as the reset button is released, the applicator resets itself and performs a vacuum test, which is audible as two quick bursts of air. If there is no blockage in the vacuum, the applicator will be ready to resume normal operation.

## **Function (cont'd)**

**OneStep Button** (square black button, top left side of unit, under reset button)

This button is used to perform the following functions:

1. Carry out the apply cycle in two steps

Pressing the OneStep button one time while a job is in the printer will cause a label to be printed and fed to the pad. By pressing this button a second time, the label will then be applied to the product.

2. Display the applicator's firmware version

If no job is in the printer, the OneStep button can be pressed and held for three seconds to display the firmware version of the applicator. The Down, Vac. and Error LEDs are used to flash the firmware version sequentially. Down = the first digit, Vac.= the second and Error = the third digit of the firmware version (e.g., Down = flash, flash; Vac. = flash; Error = flash, flash, flash. This would be Firmware version 2.13).

**Air Supply Valve** (red valve, mid to lower left front of unit)

This valve is used to perform the following functions:

1. Open or close main air supply to the applicator

When maintenance or adjustments are necessary to the applicator, the air supply should be shut off to the applicator to prevent damage to the applicator and to prevent injury to the operator. This can be accomplished by turning the air supply valve counter-clockwise. To restore the supply air, turn the air supply valve clockwise.

**CAUTION: When air is restored to the applicator, stay clear of all moving parts or serious injury can occur.**

## Function (cont'd)

### LEDs

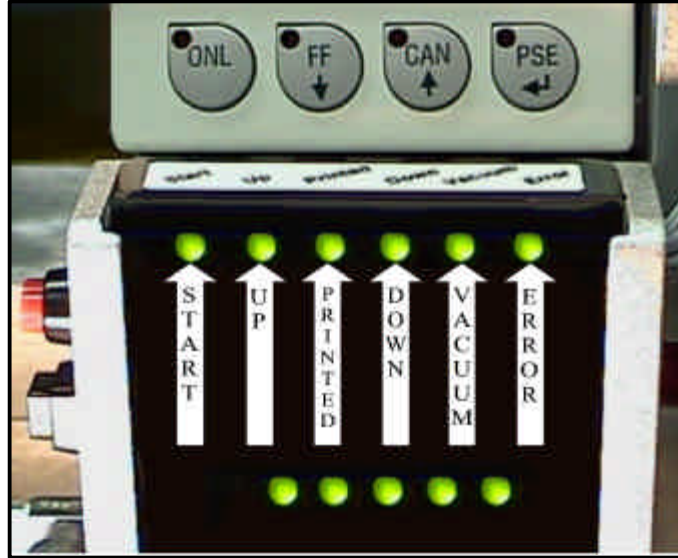

#### **START** (green, top row, first LED)

This LED indicates:

START Signal	When a START signal is supplied to the applicator, this LED is lit. The LED will remain lit for as long as the START signal is high.
--------------	--

#### **Up** (yellow, top row, second LED)

This LED indicates:

Up Position	When the applicator pad is in the up position, this LED is lit. The LED will go off as soon as the pad leaves the up position.
-------------	--

Up Error	When the pad is in the up position, and a label begins feeding to the pad, the pad must remain in the up position until the label has stopped feeding, or an up error will occur. This error can occur if the air supply to the applicator is interrupted. When this up error has occurred, the Error LED will be lit, the Up LED will flash and the Printed LED may be lit. If the pad is returned to the up position, the Up LED will stop flashing, but the error will remain until cleared by pressing the Reset button, or by sending a STOP signal to the applicator I/O port.
----------	--

If the applicator has applied a label and has not returned to the up position within 5 seconds, an up error will occur. This can occur if the air supply is interrupted, or if the cylinder becomes jammed. When this up error has occurred, the Error LED will be lit, and the up LED will flash. If the pad is returned to the up position, the up LED will stop flashing, but the error will remain until cleared by pressing the Reset button, or by sending a STOP signal on the applicator I/O port.

## **Function (cont'd)**

### **Printed** (orange, top row, third LED)

This LED indicates:

Label Printed	When the printer has finished printing a label this LED is lit. The LED will remain lit until the down position is reached, the applicator is reset, or the label is removed from the pad in one-step mode.
No Label Printed Error	<p>If the printer begins printing a label, but does not finish, the “No Label Printed Error” will occur. Normally, this error should be immediately followed by a printer error. An interruption in power can cause this error.</p> <p>When this error occurs, the Error LED will be lit, and the printed LED will flash. The error will remain until cleared by pressing the reset button, or by sending a STOP signal on the applicator I/O port.</p>

### **Down** (yellow, top row, fourth LED)

This LED indicates:

Down Position	When the applicator pad has reached the down position this LED is lit. The LED will go off as soon as the pad leaves the down position.
Down Error	<p>If the applicator begins applying a label but does not reach the down position within 3 seconds, a down error will occur. This can occur if the air supply is interrupted, or if the cylinder becomes jammed.</p> <p>When the down error has occurred, the error LED will be lit, the down LED will flash and the printed LED may be lit. If the pad is returned to the up position, the up LED may also be lit. The error will remain until cleared by pressing the Reset button, or by sending a STOP signal on the applicator I/O port.</p>

## **Function (cont'd)**

### **Vacuum** (orange, top row, fifth LED)

This LED indicates:

Label on Pad	When the applicator feeds a label to the pad, the label should block the vacuum and the vacuum LED should be lit.
Vacuum Blocked	<p>When a reset is performed, the vacuum is tested to be sure that there is no blockage of the pad or the vacuum lines. If there is blockage, the Vacuum Blocked error will occur.</p> <p>When the vacuum blocked error has occurred, the error LED will be lit, the vacuum LED will flash rapidly, and if the pad is in the up position, the up LED will be lit. This error will remain until the blockage is removed, the error is cleared by pressing the reset button, or a STOP signal on the applicator I/O port is sent. Refer to the troubleshooting section for more information on clearing a vacuum blockage.</p>
Label Not On Pad	<p>When applying a label, if the label is lost on the way down, (before reaching the down position), the Label Not On Pad error will occur.</p> <p>When the Label Not On Pad error has occurred, the error LED will be lit, the vacuum LED will flash and the printed LED may be lit. If the pad is returned to the up position, the Up LED may also be lit. This error will remain until cleared by pressing the reset button, or until a STOP signal on the applicator I/O port is sent.</p>

### **Error** (red, top row, sixth LED)

This LED indicates:

Applicator Error	When the applicator is in any error condition, this LED will be lit and will remain lit until the error is corrected and the applicator is reset by pressing the Reset button, or by sending a STOP signal on the applicator I/O port. The exact error is indicated by the flashing LED that corresponds to the error. If the error LED is lit but no other LED is flashing, the flashing LED may be stuck on by an overriding sensor. (For example, the error LED is lit, but no LED is flashing). The up LED may be on because the pad is in the up position, but if the supply air is turned off and the pad is moved from the up position, you will see that the up LED is actually flashing.
Printer Error	When the printer is in any error condition, this LED will flash, and will remain flashing until the error is corrected at the printer. This error condition can be read from the printer's front panel. The applicator will automatically reset when the error is corrected on the printer.

**Function (cont'd)**

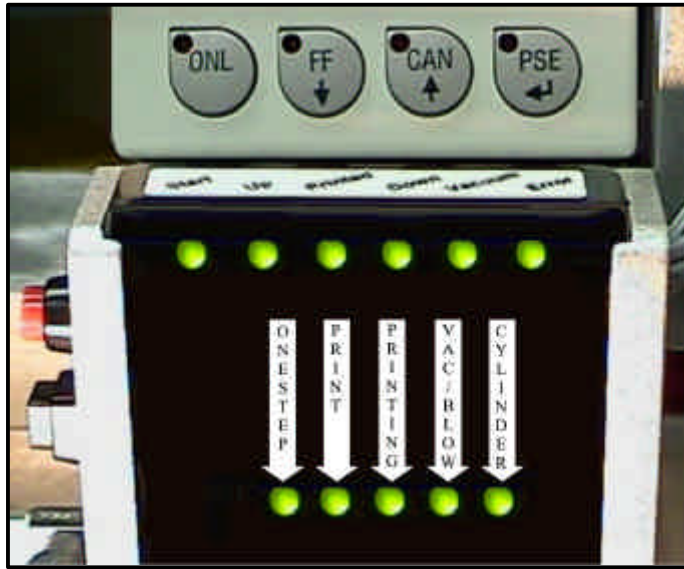

**OneStep** (orange, bottom row, first LED)

This LED indicates:

OneStep Button	When the OneStep button is pressed, this LED is lit and remains lit as long as the button is pressed.
----------------	---

**Print** (green, bottom row, second LED)

This LED indicates:

Print signal to the printer	When the pad is in the up position and the START signal is sent, or the OneStep button is pressed, the Print signal is sent to the printer. If a print job is in the printer, a label will be printed. If there is no print job in the printer, the Print signal will be ignored.
-----------------------------	---

**Printing** (orange, bottom row, third LED)

This LED indicates:

Print signal from the printer	When the printer begins printing a label, the printing signal is sent to the applicator. This signal will be sent again at the end of printing the label, just before the printed signal is sent from the printer.
-------------------------------	--

## **Function (cont'd)**

**Vac/Blow** (yellow, bottom row, fourth LED)

This LED indicates:

Vac/Blow Valve On    When the printer begins printing a label, the vac/blow valve is turned on and remains on until the down signal is received, an error occurs, the label is removed from the pad in OneStep mode, the reset button is pressed, or until a STOP signal on the applicator I/O port is sent.

**Cylinder** (yellow, bottom row, fifth LED)

This LED indicates:

Cylinder Valve On    After the label is printed and on the pad, the cylinder is turned on to apply the label (in OneStep mode, the applicator waits for the second press of the OneStep button before proceeding). The cylinder valve is turned on and remains on until the down signal is received, until an error occurs, until the reset button is pressed, or until a STOP signal on the applicator I/O port is sent.

## Function (cont'd)

### Operation

#### Printing and Applying Labels

After the applicator has been setup, the pad has been fitted, and air is being supplied, turn on the printer. Both the printer and applicator will perform setup, and self-tests. When the printer displays ONLINE, and the applicator pad is in the up position, the system is ready for operation.

A print job must be sent to the printer. This print job can come from a computer connected to the printer's serial or parallel port, or from a PCMCIA card inserted in the back of the printer. Please refer to your printer or software manual for further information on sending a job to the printer.

Once the job is ready for printing, the printer's display should read:



At this point a start signal can be sent to the printer (an optional foot switch, optical sensor or a PLC connected to the I/O Port), or the OneStep button can be pressed for manual operation. Either of these functions will cause the first label of the job to be printed and fed out to the applicator pad. If the START signal was sent, the label will then be immediately applied to the product. If the OneStep button was pressed, the pad will remain in the up position with the label on the pad until the OneStep button is pressed a second time.

When the pad comes in contact with the product, and the predetermined tamp pressure has been reached, the tamp pad will stop traveling toward the product, and it will return to the up position. When the pad has reached the up position, one labeling cycle has been completed. The applicator is now ready for the next START/OneStep signal to begin another cycle.

During each cycle, several safety and operation checks are performed to insure that the applicator is functioning correctly and that the label has been applied to the product. If any of these inspections fail, an error message will be displayed. Please refer to the troubleshooting section for a more detailed explanation of these error conditions.

## **Function (cont'd)**

### Label Synchronization

It may be necessary to discard the first label if it was not fully printed or if it did not feed correctly. This problem can occur if the labels are not positioned in the exact spot under the printhead for printing to start in the correct place. Should this problem arise, check for the following conditions:

1. The erroneous label is the first label of the first job printed on this printer
2. The printhead has been opened for changing the ribbon or labels, or for cleaning purposes
3. The label size has been changed (in software)

In most cases, the labels can be properly positioned before sending a print job to the printer. This is accomplished by pressing the FF button on the printer twice. If, at any time, one of the above-listed conditions occurs, simply discard the 2 blank labels that feed out.

If the label stock or ribbon is changed during the printing of a job, it may be necessary to discard the first label when printing is resumed.

If power is removed from the printer after the labels have been correctly positioned, power can be later restored and the labels will print normally.

## Function (cont'd)

### 15 Pin Sub-D I/O Port

The 15 pin sub-D port, which is located on the side of the applicator, allows connection to sensors, lights, timers and PLCs. This port is used to control and monitor the applicator.

Pin Assignment

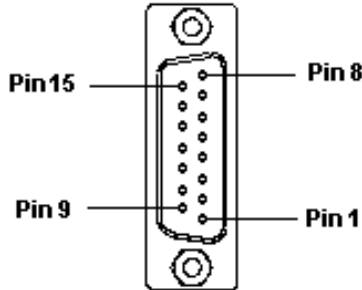

Pin	Signal	Direction	Function
1	START+	input	START signal positive
2	STOP+	input	STOP signal positive
3	P8		not defined
4	PTR_ERROR	output	printer error
5	P10		not defined
6	+5V		+5V <300mA
7	UP_I/O	output	pad in up position
8	GND		ground
9	START-	(input)	START signal negative
10	STOP-	(input)	STOP signal negative
11	P9		not defined
12	DOWN_I/O	output	pad in down position
13	APP_ERROR	output	applicator error
14	RELAY_COMMON		common for all outputs
15	+24V		+24V <1A

## Function (cont'd)

### Input Description

The inputs are optocouplers with a 750-ohm current limiting resistor in series with the input.

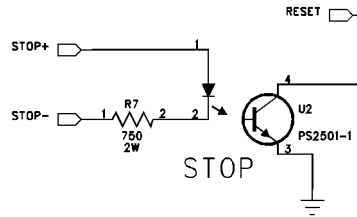
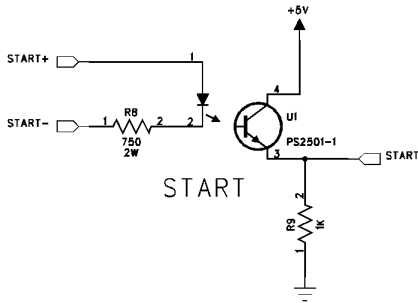

Input requirements:

START      35mA at 24V  
              7mA at 5V

STOP        35mA at 24V  
              7mA at 5V

### Output Description

The outputs are relays with one side of each relay (common) tied to pin 14.

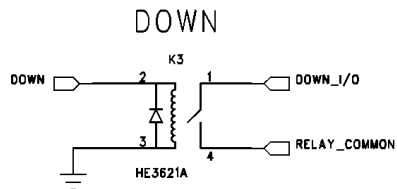
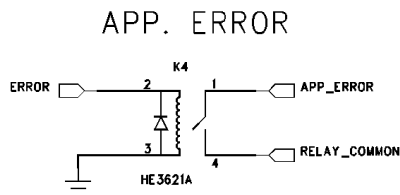
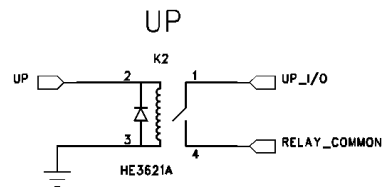
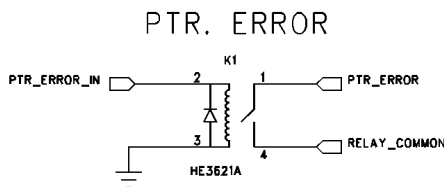

Output capabilities:

PTR\_ERROR -----\  
UP\_I/O                \  
DOWN\_I/O            /  
APP\_ERROR -----/

250mA at 40VDC  
100mA at 70VAC rms

NOT TO EXCEED  
10W DISSIPATION  
OR 100V (AC or  
DC) PEAK!

## **Function (cont'd)**

### **Signal Explanation**

#### **START+ and START- (pin 1 and 9)**

These pins are inputs for the following functions:

Control of label printing/applying	When a START signal is sent to the applicator, and a job is present in the printer, a label will be printed, fed to the pad and applied, all in one continuous process. If no job is present in the printer, the START signal will be ignored.
------------------------------------	--

These pins can be wired in the following configurations:

#### Internal 5V Power using a Microswitch

*START+(pin 1) connected to +5V (pin 6), and START- (pin 9) connected to GND (pin 8)*

This will send a START signal to the printer, and the START LED should light. Disconnecting either the +5V or the GND and then reconnecting will send another signal. For this reason, a non-powered microswitch can be placed on either the +5V side (remove wire and connect switch to pin 1 and 6) or on the GND side (remove wire and connect switch to pin 8 and 9).

#### Internal 24V Power using a Microswitch

*START+(pin 1) connected to +24V (pin 15), and START- (pin 9) connected to GND (pin 8)*

This will send a START signal to the printer, and the START LED should light. Disconnecting either the +24V or the GND and then reconnecting will send another signal. For this reason, a non-powered microswitch can be placed on either the +24V side (remove wire and connect switch to pin 1 and 15) or on the GND side (remove wire and connect switch to pin 8 and 9).

#### External High Trigger (5V to 24V)

*START+ (pin1) connected to an external high pulse ( 5 to 24V ), and START- (pin9) connected to GND (pin8, or external GND)*

When an external device, such as an optical sensor or a PLC, sends a high to the START+ (pin1) and the START- is grounded, a valid START signal is sent to the applicator and the START LED should light.

## **Function (cont'd)**

### External Low Trigger

*START+ (pin1) connected to either 5V (pin6 or external 5V) or 24V (pin15 or external 24V), and START- (pin9) connected to an external low pulse ( GND, 0V ).*

When an external device, such as an optical sensor or a PLC, sends a low to the START- (pin9) and the START+ is connected to 5 to 24V, a valid START signal is sent to the applicator and the START LED should light.

### **STOP+ and STOP- (pin 2 and 10)**

These pins are inputs for the following functions:

- |                |   |
|----------------|---|
| Emergency STOP | The applicator can be immediately stopped at any time by providing a STOP signal. The current function will cease and the applicator will return the pad to the up position and reset itself. |
| Error Reset    | When an applicator error occurs, it can be cleared by sending the STOP signal. It is important to be sure that the cause of the error is corrected, or the error may reoccur.                 |

These pins can be wired in the following configurations:

#### Internal 5V Power using a Microswitch

*STOP+(pin 2) connected to +5V (pin 6), and STOP- (pin 10) connected to GND (pin 8)*

This will send a STOP signal to the printer and the applicator will stop operating and reset itself. Disconnecting either the +5V or the GND and then reconnecting will send another signal. For this reason, a non-powered microswitch can be placed on either the +5V side (remove wire and connect to switch to pin 1 and 6) or on the GND side (remove wire and connect switch to pin 8 and 9).

#### Internal 24V Power using a Microswitch

*STOP+(pin 2) connected to +24V (pin 15), and STOP- (pin 10) connected to GND (pin 8)*

This will send a STOP signal to the printer and the applicator will stop operating and reset itself. Disconnecting either the +24V or the GND and then reconnecting will send another signal. For this reason, a non-powered microswitch can be placed on either the +24V side (remove wire and connect switch to pin 1 and 15) or on the GND side (remove wire and connect switch to pin 8 and 9).

## **Function (cont'd)**

External High Trigger (5V to 24V)

*STOP+ (pin2) connected to an external high pulse (5 to 24V), and*

*STOP- (pin10) connected to GND (pin8, or external GND)*

When an external device, such as an optical sensor or a PLC, sends a high to the STOP+ (pin2) and the STOP- is grounded, a valid STOP signal is sent to the applicator and the applicator will stop operating and reset itself.

External Low Trigger

*STOP+ (pin2) connected to either 5V (pin6 or external 5V) or 24V (pin15 or external 24V), and STOP- (pin10) connected to an external low pulse (GND, 0V)*

When an external device, such as an optical sensor or a PLC, sends a low to the STOP- (pin10), and the STOP+ is connected to 5 to 24V, a valid STOP signal is sent to the applicator and the applicator will stop operating and reset itself.

## **PTR\_ERROR and RELAY\_COMMON (pin4 and pin 14)**

These pins are outputs for the following functions:

Printer Error

When the printer is in any error condition, the PTR\_ERROR relay is energized, and will remain energized until the error is corrected at the printer. The error condition can be read from the printer's front panel. When the PTR\_ERROR relay is energized, it allows a signal to be supplied to the PTR\_ERROR line (pin 4).

The APP\_ERROR line (pin 13) flashes, indicating that the applicator is not able to function until the printer error is corrected.

The applicator will automatically reset itself when the error is corrected at the printer. The PTR\_ERROR relay will then be de-energized and the APP\_ERROR line (pin 13) will stop flashing.

These pins can be wired in the following configurations:

Source Output

*Connect the RELAY\_COMMON (pin14) to -40 to 40 VDC (this can be supplied from the port +5V on pin 6 or +24V on pin 15, or this can come from an external source), and when the relay is energized, this voltage will be supplied at PTR\_ERROR (pin4)*

Sink Output

## **Function (cont'd)**

*Connect the RELAY\_COMMON (pin14) to Ground (pin 8 of the I/O port, or an external ground, and when the relay is energized, this path to ground will be supplied at PTR\_ERROR (pin4)*

### AC Output

*Connect the RELAY\_COMMON (pin14) to 1 to 70 VAC (from an external source), and when the relay is energized, this voltage will be supplied at PTR\_ERROR (pin4)*

## **UP\_I/O and RELAY\_COMMON (pin7 and pin 14)**

This pin is an output for the following functions:

**Up Position Indicator** When the pad is in the up position, the UP\_I/O relay will be energized. The UP\_I/O relay will be de-energized as soon as the pad leaves the up position.

**Up Error Indicator** 1. If the pad is in the up position and a label begins feeding to the pad, the pad must remain in the up position until the label has stopped feeding or an up error will occur.

When this up error has occurred, the APP\_ERROR relay will be energized and the UP\_I/O relay will strobe on and off. If the pad is returned to the up position, the UP\_I/O relay will stop strobing, but the error will remain until cleared by pressing the Reset button or by sending a STOP signal on the applicator I/O port.

2. If the applicator has applied a label and has not returned to the up position within 5 seconds, an up error will occur.

When this up error has occurred, the APP\_ERROR relay will be energized and the UP\_I/O relay will strobe on and off. If the pad is returned to the up position, the UP\_I/O relay will stop strobing, but the error will remain until cleared by pressing the Reset button or by sending a STOP signal on the applicator I/O port.

These pins can be wired in the following configurations:

### Source Output

*Connect the RELAY\_COMMON (pin14) to -40 to 40 VDC (this can be supplied from the port +5V on pin 6 or +24V on pin 15, or this can come from an external source), and when the UP\_I/O relay is energized, this voltage will be supplied at UP\_I/O (pin7)*

### Sink Output

## **Function (cont'd)**

*Connect the RELAY\_COMMON (pin14) to Ground (pin 8 of the I/O port, or an external ground, and when the UP\_I/O relay is energized, this path to ground will be supplied at UP\_I/O (pin7)*

### AC Output

*Connect the RELAY\_COMMON (pin14) to 1 to 70 VAC (from an external source), and when the UP\_I/O relay is energized, this voltage will be supplied at UP\_I/O (pin7)*

## **DOWN\_I/O and RELAY\_COMMON (pin12 and pin 14)**

This pin is an output for the following functions:

Down Position Indicator	When the pad has reached the down position, the DOWN_I/O relay will be energized. The DOWN_I/O relay will be de-energized as soon as the pad leaves the down position.
Down Error Indicator	If the applicator begins applying a label but does not reach the down position within 3 seconds, a down error will occur.  When the down error has occurred, the APP_ERROR relay will be energized and the UP_I/O relay will strobe on and off. The error will remain until cleared by pressing the Reset button or by sending a STOP signal on the applicator I/O port.

These pins can be wired in the following configurations:

### Source Output

*Connect the RELAY\_COMMON (pin14) to -40 to 40 VDC (this can be supplied from the port +5V on pin 6 or +24V on pin 15, or this can come from an external source), and when the DOWN\_I/O relay is energized, this voltage will be supplied at DOWN\_I/O (pin12)*

### Sink Output

*Connect the RELAY\_COMMON (pin14) to Ground (pin 8 of the I/O port, or an external ground, and when the DOWN\_I/O relay is energized, this path to ground will be supplied at DOWN\_I/O (pin12)*

### AC Output

*Connect the RELAY\_COMMON (pin14) to 1 to 70 VAC (from an external source), and when the DOWN\_I/O relay is energized, this voltage will be supplied at DOWN\_I/O (pin12)*

## **Function (cont'd)**

### **APP\_ERROR and RELAY\_COMMON (pin13 and pin 14)**

This pin is an output for the following functions:

Applicator Error	When the applicator is in any error condition, the APP_ERROR will be energized, and will remain energized until the error is corrected and the applicator is reset by pressing the Reset button or by sending a STOP signal on the applicator I/O port. The exact error is indicated by the corresponding flashing LED. If the error LED is lit but no other LED is flashing, the flashing LED may be stuck on by an overriding sensor. For example, the Error LED could be lit, but no LED is flashing. The Up LED may be on because the pad is in the up position, but if the supply air is turned off and the pad is moved from the up position, you will see that the Up LED is actually flashing.
------------------	--

These pins can be wired in the following configurations:

#### Source Output

*Connect the RELAY\_COMMON (pin14) to -40 to 40 VDC (this can be supplied from the port +5V on pin 6 or +24V on pin 15, or this can come from an external source), and when the APP\_ERROR relay is energized, this voltage will be supplied at APP\_ERROR (pin13)*

#### Sink Output

*Connect the RELAY\_COMMON (pin14) to Ground (pin 8 of the I/O port, or an external ground, and when the APP\_ERROR relay is energized, this path to ground will be supplied at APP\_ERROR (pin13)*

#### AC Output

*Connect the RELAY\_COMMON (pin14) to 1 to 70 VAC (from an external source), and when the APP\_ERROR relay is energized, this voltage will be supplied at APP\_ERROR (pin13)*

## Application Notes

The following is a list of factors to consider when placing the applicator and optical sensor on a conveyor:

The second box back should not trip the optical sensor until the pad has returned to the up position. If this occurs, the label placement will be delayed and cause the label to be positioned too far back or off the back of the box. Long boxes will not cause a problem. The applicator will not begin the print and apply cycle until the sensor has been reset (turned off by the absence of a box), and then triggered again by another box.

**If the label is too far back on the box, or product,** move the sensor away from the applicator. This will cause the box to trip the sensor sooner, which allows the applicator more time to put the label on the box. The label will then be applied sooner, and therefore closer, to the front of the box or product.

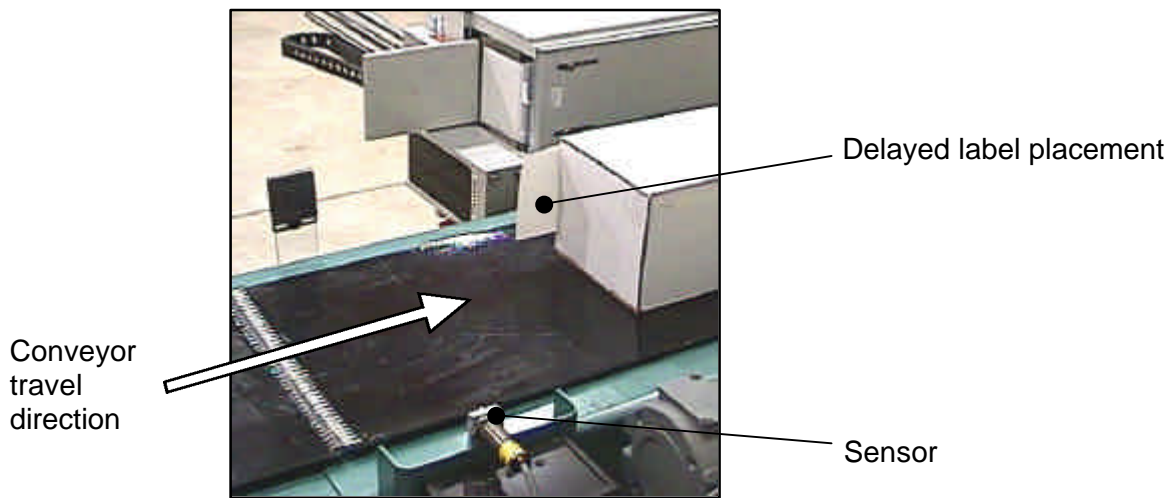

**If the label is too far forward on the box or product,** move the sensor toward the applicator. This will cause the box to trip the sensor later, which allows the applicator less time to put the label on the box. The label will then be applied later, and therefore further, towards the back of the box or product.

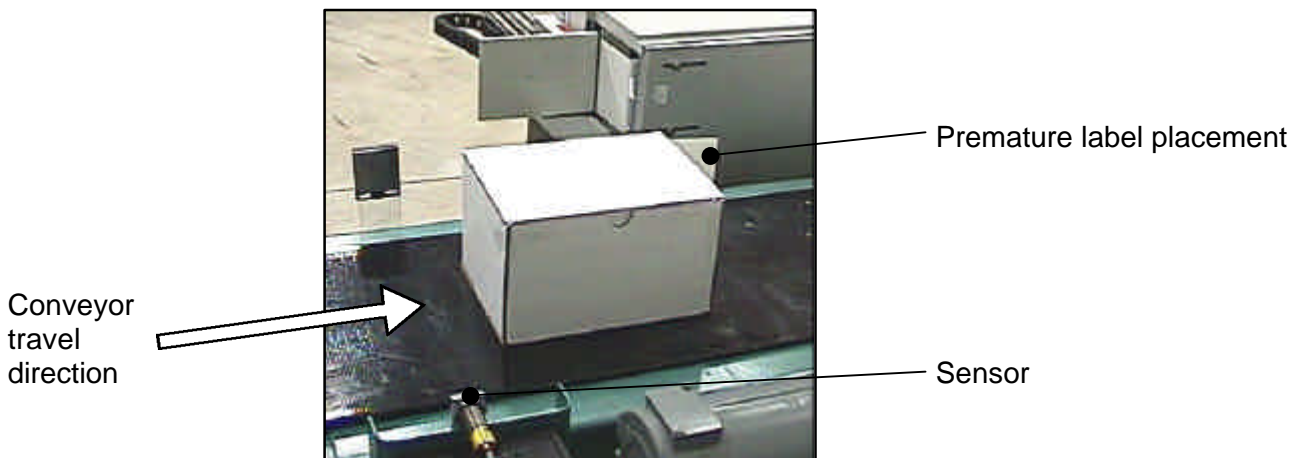

## Application Notes (cont'd)

The optional timer can also be used to adjust the placement of the label. This is accomplished by delaying the start signal using a preset delay in the timer. This can be used for fine-tuning the label placement. It may be useful in applications where the sensor mounting position is limited and does not allow the sensor to be moved in order to adjust label placement. The main use of the timer is to allow accurate placement of a label in the middle of a box when jobs that use different length boxes are done on the same line.

The conveyor speed must remain constant for the label placement to be consistent. If the conveyor speed fluctuates, the label placement will be erratic.

## Firmware

Checking the applicator's firmware version:

*When there is no job in the printer, press and hold the OneStep button for three seconds. The last three LEDs (down, vacuum and error) will begin flashing in order. Continue to hold the OneStep button in order to keep the LEDs flashing. The flashes will correspond to the number for each digit.*

For example:

DOWN LED flashes once = 1  
VAC LED flashes three times = 3  
ERROR LED flashes five times = 5  
Firmware version = 1.35

*(In order to prevent confusion, zeros are not used in the firmware version.)*

Downloading new firmware:

***(Please note that this feature will not be available until the third quarter of 2000.)***

The applicator firmware can be upgraded as needed in the field without hardware changes. The firmware is stored in flash memory and new firmware can be downloaded to the applicator mainboard through the 9-pin serial connector on top of the mainboard using a standard null modem cable connected to your computer.

## Application Notes (cont'd)

Upgrading firmware:

If there is power to the Apollo printer at this point, turn it off before proceeding. The cover screwset is located on the upper front of the left side of the applicator.

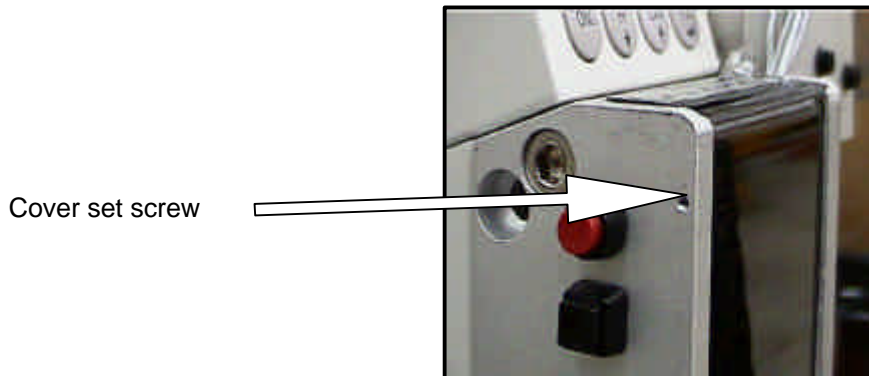

Loosen this screw - do not remove it. Slide the front cover up and completely off of the applicator.

Locate the 9-pin serial connector on the back, top of the applicator mainboard. Connect one end of a 9-pin null modem serial cable to this connector.

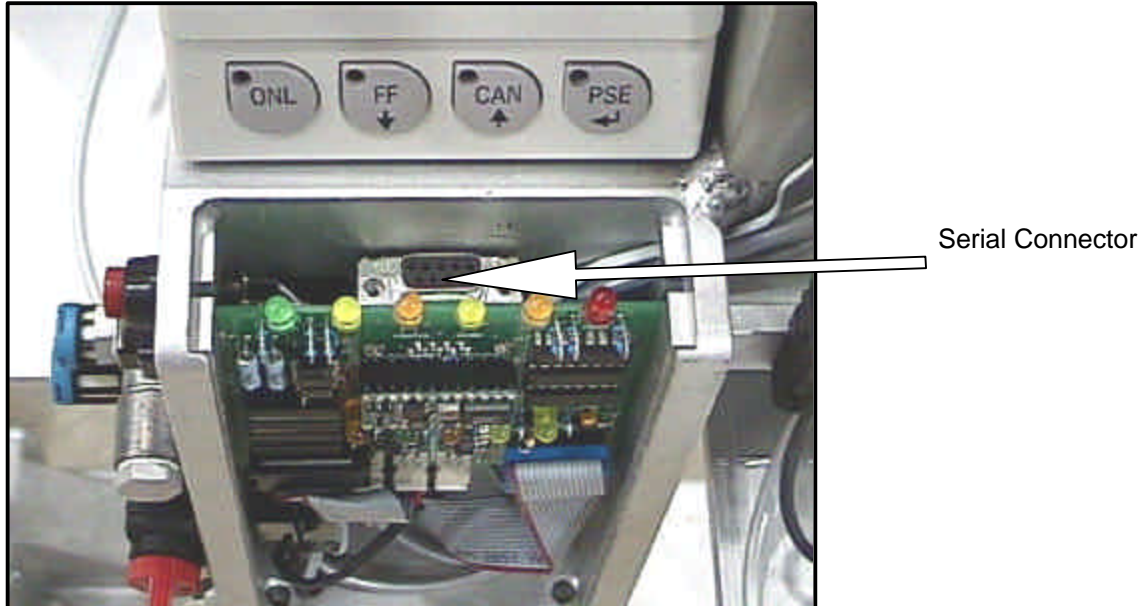

Connect the other end to your PC serial port and turn on the printer.

Start the firmware upgrade utility and follow the onscreen instructions.

## **Troubleshooting**

### **Error Conditions, Causes and Solutions**

#### *Up Error (the Error LED will be lit, and the Up LED will flash)*

The up error occurs under one of the following conditions:

1. The pad stays in the up position after label feeding.
2. The pad does not return to the up position within three seconds of reaching the down position.
3. The up sensor has malfunctioned or has been moved.
4. The applicator mainboard has malfunctioned.

Probable causes:

1. There is a permanent/temporary loss or drop of air supply pressure.
2. The cylinder is jammed by a moving object that has pulled the pad from the up position or by an object that is blocking it from returning to the up position.
3. The up sensor clamp has been damaged or has worked loose from its original position. The sensor is no longer in the correct position to sense that the pad is in the up position.

Solutions:

1. A larger compressor or larger supply lines may be required to maintain the necessary air pressure to the applicator. The applicator requires 5 CFM between 5 and 6 bar (90psi).
2. Install the necessary guards or safety rails to prevent external obstructions, such as fingers, hands or arms, machinery, or surrounding product or packaging, from interfering with the labeling process at the applicator.
3. Reposition the up sensor to the correct position on the cylinder shaft. The lip around the top of the sensor should roughly line up with the bottom of the down stroke adjustment valve. When the pad is the up position, the up LED should be on. If you move the pad out of the up position, the LED should be off. If the LED is on and then goes off and back on as the pad is moved out of the up position, the sensor is positioned too low. Move the sensor up and try again.
4. The applicator may need servicing. Replace the faulty sensor or mainboard.

#### *Printed Error (the Error LED will be lit, and the Printed LED will flash)*

The printed error occurs under one of the following conditions:

1. The printer begins printing a label, but does not finish.
2. The PRINTING signal is given by the printer, but the printer never gives the PRINTED signal.

## **Troubleshooting (cont'd)**

Probable causes:

1. The power to the printer was interrupted during operation.
2. The printer has malfunctioned.

Solutions:

1. Check the power cord to the printer; it may be loose or damaged. Reset or replace the plug, if necessary.
2. Service the printer.

*Down Error (the Error LED will be lit, the down LED will flash and the Printed LED may be lit)*

The down error occurs under one of the following conditions:

1. The applicator begins applying a label but does not reach the down position within 3 seconds.
2. The down sensor is malfunctioning, and therefore cannot detect the pad in the down position.

Probable causes:

1. The cylinder is jammed.
2. The product to be labeled is not present at the time the pad has reached the labeling position.
3. The down sensor has malfunctioned or has been moved.
4. The applicator mainboard has malfunctioned.

Solutions:

1. Install the necessary guards or safety rails to prevent external obstructions, such as fingers, hands or arms, machinery, or surrounding product or packaging, from interfering with the labeling process at the applicator.
2. Check the product flow and product sensors. The product may be obstructed from entering the labeling position, or the product sensor may be triggering falsely when no product is present.
3. The applicator may need to be serviced. Replace the faulty sensor or mainboard

## **Troubleshooting (cont'd)**

### *Vacuum Blocked Error (The Error LED will be lit, the Vacuum LED will flash rapidly)*

This error occurs when the vacuum is being tested at power up, or after the reset button is pressed under one of the following conditions:

1. The holes on the pad are covered.
2. The channels in the pad are blocked.
3. The vacuum lines running to the pad are blocked.
4. The pneumatics are blocked.
5. The vacuum sensor has malfunctioned.
6. The applicator mainboard has malfunctioned.

Probable causes:

1. There is a label stuck on the pad.
2. Dust, dirt or some other foreign substance has caused a blockage in the pad, vacuum lines or pneumatics.
3. Water or oil from the main air supply has accumulated in the pneumatics.

Solutions:

1. Remove the stuck label from the pad.
2. Remove the blockage, or replace the blocked components.
3. Install the necessary filters to remove all water and oil from the supply air.
4. The applicator may need to be serviced. Replace the faulty sensor or mainboard.

### *Label Not On Pad Error (the Error LED will be lit, the Vacuum LED will flash and the Printed LED may be lit)*

This error occurs under one of the following conditions:

1. The label was printed and fed out to the pad, but all of the holes on the pad were not covered.
2. The label was printed and fed to the pad, and the holes were covered, but when the pad started moving, the label was pulled off of the pad by the edge of the label still in the printer or by the liner.
3. The label did not stay on the pad long enough to reach the product.
4. The vacuum sensor has malfunctioned.
5. The applicator mainboard has malfunctioned.

## **Troubleshooting (cont'd)**

Probable causes:

1. The label is too small for the pad or the holes are in the wrong place for the size label that is being used.
2. The presentation position is set too high, therefore causing the next label to hang over the peel edge and intercept the printed label on the way down to the product.
3. The presentation position is too small and the printed label's trailing edge did not separate from the liner. The label is pulled off of the pad on the way to the product.
4. Something has intercepted the label from the pad on the way to the product.

Solutions:

1. Be sure to use the correct pad for the label size that you are using.
2. Adjust the presentation position to between 6 and 12 as a starting point. There may be slight manufacturing tolerances that vary from printer to printer that will make it necessary to change this setting. The presentation position should be set so that the second label's leading edge is 1mm behind the peel edge when the first label out has stopped moving and is on the pad. This can be checked with the OneStep button.
3. Check for and eliminate any obstructions that may prevent the label from not reaching the product.
4. The applicator may need to be serviced. Replace the faulty sensor or mainboard.

*24V external device attached to the I/O port has no power, or loses power after printing a job.*

This problem occurs under the following conditions:

1. The 24V device works only while a print job is in the printer

Probable causes:

1. The "24V on" setting in the printer is set to "printing only".

Solutions:

1. Change the "24V on" setting in the printer to "permanent". Refer to the printer maintenance manual for instructions on where to find this setting, and how to change it. This setting should be factory set to "24V on: permanent".

## **Troubleshooting (cont'd)**

### Problems, Causes and Solutions

#### *The Labels are Not Reaching the Pad and / or You See Overlapping Fields*

This problem occurs when the labels are slipping on the drive roller.

Probable cause:

1. The drive roller is dirty. Paper, dust, adhesive, and/or a label is on the drive roller.
2. The print speed is too high.

Solutions:

1. Clean the drive roller.
2. Decrease the print speed to the slowest possible speed for the job. It is not recommended to use a print speed over 5.2ips when using the PA1000t.

#### *The Tamp Pad is Stopping Before Completing the Full Down Stroke*

This problem occurs when the label or tamp pad is too close to the peel edge.

Probable causes:

1. The label is being fed too far and the second label is hanging over the peel edge.
2. The label is not being fed out far enough to separate from the liner.
3. The applicator is damaged; the pad is too close to the peel edge and is making contact with it on the way down.

Solutions:

1. Reduce the presentation position until the second label out is 1mm in back of the peel edge.
2. Increase the presentation position until the printed label separates from the liner and the second label out is 1mm in back of the peel edge.
3. Service the applicator.

## **Troubleshooting (cont'd)**

### *Thin White Line Across the Format*

This problem occurs under one of the following conditions:

1. The backfeed setting in the printer's front panel is set to smart.
2. The label stock is being pulled from the printer.
3. The label stock is not traveling at a constant rate.

Probable causes:

1. The printer was not properly configured.
2. The rewind tension is too high.
3. The printer has buildup or wear on the drive roller.

Solutions:

1. Change the back feed setting in the printer's front panel to 'always'.
2. If possible, move the fields in the area of the line so that the line falls in the white space and is not visible.
3. Reduce the rewind tension.
4. Service the printer.

### *The First Label in the Job is Not Placed Correctly (when using a conveyor)*

This problem occurs when the backfeed setting in the printer's front panel is set to smart.

Probable cause:

When the first label is printed, the entire label and part of the second label is actually printed. This takes longer than when the second label is printed, since part of it has already been printed. For this reason, the first label will be applied slightly later than the rest of the labels. This means that, on a conveyor, it will be applied later to the product than the rest of the labels in that job.

Solution:

Change the backfeed setting in the printer's front panel to 'always'.

## **Troubleshooting (cont'd)**

### *The Labels Are not applied to the Same Place on the Product (when using a conveyor)*

This problem occurs under the following conditions:

1. The product is not traveling at a consistent speed.
2. The leading edge of the product triggers the sensor too soon.
3. The leading edge of the next product triggers the sensor before the pad has returned to the up position.

Probable causes:

1. The speed of the conveyor is not constant.
2. The size of the product varies.
3. The product is not straight as it approaches the sensor.

Solutions:

1. Regulate the speed of the conveyor so that it remains constant.
2. Keep in mind that the label will always be applied at the same distance from the leading edge of the product, so if different size products are used, the label will not always be applied to the middle of each product.
3. Guide rails may be necessary to align products on the conveyor as they approach the applicator.

### *Random errors when the pad makes contact with the product*

This problem occurs under the following conditions:

2. The product is being pushed or slid into position for labeling.
3. The product is insulated from ground (example- products on a plastic pallet).

Probable causes:

1. ESD (electrostatic discharge). Static charge can buildup on a product during movement into the labeling position. The charge is then discharged through the printer/applicator to ground when the pad makes contact with the product.

Solutions:

2. Install a static discharging device such as a static discharge brush. The brush should contact the product before the applicator. This will allow the static to discharge through the brush to ground before it discharges through the printer or applicator, potentially causing the printer or applicator to display random errors.

## **Troubleshooting (cont'd)**

### **Common Problems with Setup or Media**

*Pressure changes in the supply air are one of the most common causes of fluctuations in the performance of a label printer/applicator and other pneumatic devices.*

A sudden drop in the supply air pressure can occur if the air supply lines are inadequate and cannot handle periodic pressure drops. These pressure drops can take place during the initialization and operating cycles of pneumatic equipment. As a result, the label can either jam or not be applied to the product. This problem is very difficult to identify due to its random nature. For example, the air pressure will already have returned to normal levels by the time an operator or maintenance person arrives to repair the equipment.

Attempting to identify and diagnose equipment problems will be ineffective, since the real culprit is ultimately the air supply. This dilemma can be resolved with a pneumatic monitoring device, such as Festo part number 9349APL-2N-PEV, which continuously monitors the air supply line for pressure drops. When the air pressure drops to a preset level, a beacon light on the label primer/applicator automatically signals to the operator that the air pressure has dropped below the required pressure level.

### *Unique Label Mode*

The unique label mode is the most demanding application because each label is different from the previous one. Each label to be printed must be sent from a computer. The label is then printed and applied to the product, and the PA1000t is ready for the next label. This requires continuous communication between the computer and the label PA1000t. Complications will arise if the label information is not sent in time, if a communication error occurs or if the label PA1000t is out of labels or ribbons. All of these factors add to the complexity of the system.

### *Supply Problems*

The standard labels for use with most label printers consist of a label sandwich and the following components:

- \* Liner or carrier sheet
- \* Liner release coating
- \* Adhesive
- \* Label material
- \* Label topcoat

The ribbons consist of the following materials:

- \* Silicone
- \* Carrier sheet
- \* Wax or resin ink

## **Troubleshooting (cont'd)**

The most common supply problems are as follows:

### **1) Mismatch of supplies**

Problems involving thermal transfer printing:

1. Poor print quality
2. Ink smearing
3. Poor ink adhesion to label

Probable causes:

1. Wax based ribbons are being used on synthetic label stocks
2. Resin-based ribbons used on paper label stock
3. Use of labels were not developed for a thermal transfer printer

Problems for thermal printers:

1. Poor print quality
2. Premature printhead
3. Failure

Probable causes:

1. The label stock requires a higher or lower heat setting in the printer
2. The thermal coating is too abrasive

### **2) Die strikes**

Problem:

The labels are difficult to peel off or are not being removed consistently from the backing.

Probable cause:

The gap between the cutting die and the anvil was set incorrectly on the press. The result can either be a die strike that is too deep or too shallow. A deep die strike breaks through the liner surface, thereby exposing the paper interior to the adhesive. The adhesive then grips the liner, which can make stripping difficult. To test for this, use a black felt-tipped marker to outline the die cutting area. If a solid black line appears along the die cut, the die strikes are too deep. A shallow die strike will not properly cut through the adhesive and could leave adhesive 'legs' that hold on to the label stock.

## **Troubleshooting (cont'd)**

### **3) Incorrect release specification**

Problems:

1. Labels lift up or drop off as the label web is pulled through the machine.
2. Labels difficult or impossible to peel.

Probable causes:

1. During label construction, the adhesive coater can adjust the amount of release agent on the liner that will affect the amount of tension required to release a label from the liner. If the labels are lifting as they travel through the equipment, the release was set too low during label construction.
2. If labels are difficult to peel off, the release was most likely set too high.

### **4) Core diameter**

Problem:

Problems arising with the core diameter are most common in applications that require the use of five inch labels or longer. Labels near the end of the label roll have a permanent curl that will make it difficult for the vacuum system to hold the label in place on the applicator pad.

Probable cause:

The label roll ID is too small, (the standard core size is 3"). Any label five inches or longer should use a 5" ID label core.

### **5) Label winding tension**

Problems:

1. The label liner sticks as the labels are unwound from the roll, adhesive buildup is visible on equipment rollers
2. The label rolls are difficult to pick up and mount because the center core falls out or telescopes

Probable causes:

1. If the labels are wound too tight, adhesive can escape from under the label, which causes the liner to stick.
2. If the labels are wound too loosely, the core can fall out. For this reason, it is crucial that the label supplier has the experience and knowledge required to specify and monitor the correct wind to avoid any potential tension problems.

## **Troubleshooting (cont'd)**

### **6) Label length varies**

Problem:

In applications where the label must fit within a tight space, the label will occasionally be too large or too small on the same roll, which can cause the label printer to periodically lock up and display a label length error message.

Probable cause:

The label converter used the incorrect web tension during the die cutting operation.

### **7) Label liner stiffness/ weight**

Problems:

1. The label is difficult to peel.
2. The liner breaks.

Probable causes:

1. The liner is too thick for the label printer or applicator peel bar, and therefore does not provide enough release tension for the label.
2. The liner is too thin and will break from the label web tension as it is pulled through the machine. This condition can be aggravated when there are die strikes on the liner.

### **8) Label stiffness**

Problem:

As the label is peeled from the backing, the label wrinkles or falls off the applicator pad.

Probable cause:

As the label is stripped from the backing, a minimum label stiffness is required to move the label out from under the applicator pad. Labels lacking sufficient stiffness tend to curl and fall off the pad.

## **Troubleshooting (cont'd)**

### **9) Insufficient testing**

It is strongly recommended that any changes in the supplies undergo thorough testing. This, however, does not mean carrying out a test run with the supplies on a machine for one day, but rather a test should be carried out throughout its *required useful life*. For example, a label intended for use within a manufacturing plant or warehouse will have different testing requirements than a label that must withstand the rigors of being shipped across the desert in the summer or stored in an unheated warehouse in Minneapolis in the winter.

### **10) Environmental changes**

Label stocks normally perform better in colder temperatures because the adhesive is less tacky. Always store labels in the same room/environment as the PA1000t for at least 24 hours before use.

When choosing the label stock, we recommend that you contact the label manufacturer to request stock that is guaranteed to dispense on a standard tabletop printer. All testing on the PA1000t has been carried out using Fasson® TransTherm 1C with 2501 Adhesive.

## Warning Beacon Instructions



The warning beacon functions as a visual display for applicator and printer errors.

The warning beacon indicates two different errors.

- When there is a printer error, the warning beacon will flash.
- When there is an applicator error, the warning beacon will go on and stay on.

When the error is cleared the light will be off.

Connections:

The warning beacon is connected to the I/O port of the applicator with the supplied Y-cable. Be sure that the male connector of the Y-cable is connected to the I/O port of the applicator. One of the female connectors should be connected to the warning beacon. The other female connector can be connected to the optical sensor, timer, foot switch, or PLC.

**WARNING!** Be sure to remember that the Y-cable can allow the same pin of the I/O port to be used in two places at the same time. Never use the Y-cable in a manner that will allow devices to conflict with each other, such as an optical sensor on one end, and a timer on the other. This will blow the power supply in the printer, and can damage the devices as well as the applicator. Only use the Y-cable as described above to prevent problems.

When wiring a PLC, take note of the warning beacon connections in figures 1.

Figure 1

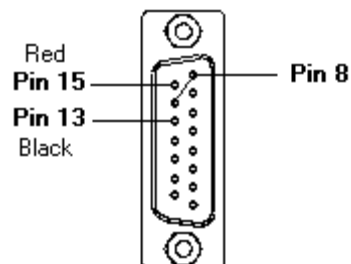

Pin 15 is 24v which is supplied to the light.  
Pin 14 is the error reverse line which is tied to pin 8 which is ground.  
Pin 13 is the applicator error which is tied to the negative of the light.

## Product Sensor Instructions

The product sensor functions as an automatic trigger device, which sends a start signal to the applicator. The product sensor senses its invisible beam when reflected from the supplied reflector. The yellow indicator LED on the back of the sensor will not be lit when the beam is sensed. When the beam is broken, the yellow LED will light, and the start signal is sent to the device that the sensor is connected to, (applicator, timer, or PLC). The reflector can be mounted up to 9 feet away from the sensor. The sensor is not affected by ambient light, or reflective surfaces that are not polarized, (the reflector is polarized).



### Connections:

The product sensor can be plugged directly into the I/O port of the applicator, or it may be attached to the female port on the optional product sensor timer, or you may attach it to a PLC for automated applications.

### Application Notes

The following is a list of factors to consider when placing the applicator and optical sensor on a conveyor:

The second product back should not trip the optical sensor until the pad has returned to the up position. If this occurs, the label placement will be delayed and cause the label to be positioned too far back or off the back of the product. Long products will not cause a problem. The applicator will not begin the print and apply cycle until the sensor has been reset (turned off by the absence of a product), and then triggered again by another product.

**If the label is too far back on the product**, move the sensor away from the applicator. This will cause the product to trip the sensor sooner, which allows the applicator more time to put the label on the product. The label will then be applied sooner, and therefore closer, to the front of the product.

**If the label is too far forward on the product**, move the sensor toward the applicator. This will cause the product to trip the sensor later, which allows the applicator less time to put the label on the product. The label will then be applied later, and therefore further, towards the back of the product.

The optional product sensor timer can also be used to adjust the placement of the label. This is accomplished by delaying the start signal using a preset delay in the timer. This can be used for fine-tuning the label placement. It may be useful in applications where the sensor mounting position is limited and does not allow the sensor to be moved in order to adjust label placement. The main use of the timer is to allow accurate placement of a label in the middle of a product when jobs that use different length products are done on the same line.

The conveyor speed must remain constant for the label placement to be consistent. If the conveyor speed fluctuates, the label placement will be erratic.

## **Product Sensor Timer Instructions**

The product sensor timer functions as a 'start delay' or a 'start pulse generator'.

The purpose of the 'start delay' function is to delay the start pulse that is sent from the product sensor. The user sets the delay in the timer, the higher the number the longer the delay. The typical use for this function is to allow for label placement in the middle of the a box when different length boxes in separate jobs on the same conveyor, or to allow a sensor to be mounted to a conveyor in a fixed location, and use the delay value to 'fine tune' the placement of the label. This may be necessary in cases where there is a limited amount of space for the sensor to be mounted, which does not allow adequate adjustment of the sensor to correctly position the label on the product.



The purpose of the 'start pulse generator' function is to produce a start pulse at a timed interval. The user sets the interval in the timer, the higher the number the longer the interval between start pulses. The typical use for this function is to allow a scale to be used in an automated application. After the product is on the scale, and the weight data is sent to the label, the label is ready to print and be applied. The continuous stream of start pulses assures that the label is printed and applied when it is ready.

### Connections:

The timer is connected to the I/O port of the applicator with the supplied 6' timer cable. Be sure that the male connector on the right side of the timer is connected to the I/O port. This will allow the start signal to be sent to the applicator. The female port on the left of the timer will pass through all connections to the I/O port except the start signal. Note: If it is necessary to pass the start signal through the timer, set the timer to 'delay' mode, and set the value to '0000'.

### Settings:

To set the timer,

- Press the 'select' button, a cursor will blink over the first character of the mode.
- Press the 'up' or 'down' button to scroll through the list of modes 'Off', 'Delay', and 'Strobe'.
- Accept the desired mode and value by pressing 'enter',  
Or, change the value after the mode by pressing 'change'
- A cursor will blink over the first digit.
- Press the 'up' or 'down' buttons to change that digit,  
Or, press the 'change' button to move to the next digit.
- Accept the value at any time by pressing the 'enter' button.

The timer will not send a start signal when it is set to 'Off' or when the cursor is blinking over the mode or value. The last set mode and value will be retained, and used upon power-up only if the 'enter' button has been pressed to accept the setting, otherwise the value that was saved by pressing the 'enter' button will be used.

## Foot Switch Instructions



The foot switch functions as a manual trigger device, which sends a start signal to the applicator when it is pressed.

### Connections

The foot switch can be plugged directly into the I/O port of the applicator, or it may be attached to the female port on the optional product sensor timer, or you may attach it to a PLC for semi-automated applications.



## **WARRANTY INFORMATION**

### **1. Applicator Warranty**

THARO Applicators are warranted against defects in material or workmanship for a period of 12 months (365 days) or 1,000,000 cycles of use from the date of original shipment by THARO SYSTEMS, INC. This warranty does not cover normal wear and tear and shall be null and void if the equipment is modified, improperly installed or used, damaged by accident or neglect, or in the event any parts are improperly installed or replaced by the user.

---

THARO SYSTEMS' SOLE OBLIGATION UNDER THIS WARRANTY SHALL BE TO FURNISH PARTS AND LABOR FOR THE REPAIR OR REPLACEMENT OF PRODUCTS FOUND TO BE DEFECTIVE IN MATERIAL OR WORKMANSHIP DURING THE WARRANTY PERIOD.

---

As a condition of this warranty, the user must: (a) obtain a THARO Return Authorization for the applicator or subassembly (s); (b) ship the applicator or subassembly (s), transportation prepaid to the authorized service location; and (c) include with the Product or subassembly (s) a written description of the claimed defect. Unless THARO SYSTEMS authorizes return of the entire Product, the user shall return only the subassembly (s). Products returned shall be packaged in the original packing and shipping container or comparable container. In the event equipment is not so packaged or if shipping damage is evident, it will not be accepted for service under warranty. Surface transportation charges for the return of the applicator to the customer shall be paid by THARO SYSTEMS within the 48 contiguous states and the District of Columbia. Customer shall pay shipping costs, customs clearance, and other related charges outside the designated area. If THARO SYSTEMS determines that the Product returned to it for warranty service or replacement is not defective as herein defined, BUYER shall be subject to a minimal labor charge and all costs of handling and transportation.

### **2. Warranty Exclusions and Conditions**

The above warranties are in lieu of all other warranties, expressed or implied, oral or written, statutory or otherwise, including any implied warranty of merchant-ability or fitness for a particular purpose.

THARO SYSTEMS shall not be responsible for the specific application to which any Products are applied, including but not limited to compatibility with other equipment.

All statements, technical information and recommendations relating to THARO Products are based upon tests believed to be reliable but do not constitute a guarantee or warranty.

---

THARO SYSTEMS SHALL NOT, UNDER ANY CIRCUMSTANCES WHATSOEVER, BE LIABLE TO BUYER OR ANY OTHER PARTY FOR LOST PROFITS, DIMINUTION OF GOODWILL OR ANY OTHER SPECIAL OR CONSEQUENTIAL DAMAGES WHATSOEVER WITH RESPECT TO ANY CLAIM HEREUNDER. IN ADDITION, THARO SYSTEMS' LIABILITY FOR WARRANTY CLAIMS SHALL NOT, IN ANY EVENT, EXCEED THE INVOICE PRICE OF THE PRODUCT CLAIMED DEFECTIVE, NOR SHALL THARO SYSTEMS BE LIABLE FOR DELAYS IN REPLACEMENT OR REPAIR OF PRODUCTS

---

No salesperson, representative or agent of THARO SYSTEMS is authorized to make any guarantee, warranty, or representation in addition to the foregoing warranty.

---

NO WAIVER, ALTERATION, ADDITION, OR MODIFICATION OF THE FOREGOING WARRANTIES SHALL BE VALID UNLESS MADE IN WRITING AND SIGNED BY AN EXECUTIVE OFFICER OF THARO SYSTEMS

---



## INDEX

### 1

15-pin sub-d connector.....1,15,39

### A

Air regulator ..... 9, 16, 17, 30, 31  
Applicator .....1, 2, 4, 5, 7, 18-29, 34, 46, 63  
Applicator front cover ..... 15  
Applicator plate ..... 14  
Applicator specifications ..... 1, 5

### B

Base clamp .....7, 10, 11  
Blow bar..... 4, 17  
Blow tube ..... 2, 17

### C

Cleaning..... 9  
Core adapter .....7, 20, 21  
Cover set screw ..... 15

### D

Down stroke speed..... 22  
Draining ..... 9

### E

EASYLABEL® Software ..... 3, 6, 29  
Error conditions, causes, and solutions..... 50  
ESD ..... 56

### F

Firmware ..... 31, 48  
Front panel..... 3, 4, 28, 34, 43, 55  
Function ..... 30-46

### G

Guide rod ..... 9

### I

Input description..... 40

### L

Label placement.....6, 47, 48  
Label synchronization..... 1, 38  
LCD ..... 28  
LED.....1, 4, 31-36, 41, 42, 46, 48, 50-52

### M

Main mast ..... 11, 16

### O

OneStep button..... 29, 30, 31, 35, 36, 37, 48  
Operation ..... 1, 37  
Options ..... 1, 6  
Output description ..... 1, 40

### P

PCMCIA card ..... 37  
Peel plate..... 14  
Peripheral port..... 2, 15  
Pin assignment..... 39  
Plate release lever..... 13  
PLC..... 2, 4, 37, 41, 42, 43  
Printer error..... 34, 43  
Printer index holes..... 2, 13  
Printer setup..... 1, 28  
Problems, causes and solutions ..... 1, 54

### R

Regulator hose ..... 7, 17  
Reset button..... 30

### S

Safety instructions ..... 8, 9  
Sensor .....2, 4, 34, 37, 41-43, 46-47, 50, 53, 56  
Serial connector ..... 49  
Shipment contents..... 7  
Side arm clamp ..... 7, 11  
Signal explanation ..... 1, 41  
Software setup ..... 1, 29  
Support plate..... 7, 12

### T

Table clamp ..... 7, 12  
Table pins ..... 2, 13  
Table support .....7, 11, 12  
Tamp angle..... 1, 22  
Tamp orientation ..... 1, 18  
Tamp pad..... 1, 4, 7, 8, 15, 16, 22, 24, 25, 37, 54  
Tamp pressure ..... 24  
Tamp speed ..... 22  
Tear plate..... 14  
Tools required ..... 1, 10  
Troubleshooting ..... 50- 61

### U

U-bolt bracket..... 16  
Up stroke speed ..... 23

### V

Vacuum.....9, 16, 34, 52

### W

Warranty ..... 1, 67

